

Installation & Operating Manual

Please read this manual carefully before attempting to install, operate or maintain the product described. Failure to comply with the information provided in this manual could result in personal injury and/or property damage. Retain this manual for future reference.

Laing Sealless Centrifugal Canned Motor Pumps

Bronze Housing Models
60 cycle

SM-303-B
SM-909-B-14
SM-909-B
SM-909-B-26
SM-1212-B-26

Description

Laing centrifugal pumps are designed for circulation and transfer of a variety of fluids compatible with their materials of construction limited to maximum fluid temperatures and maximum line pressures as indicated below. Unique leakproof integrated motor/pump design eliminates the need for conventional mechanical seals or other shaft sealing devices. They are self lubricating and require no external lubrication.



Dimensions

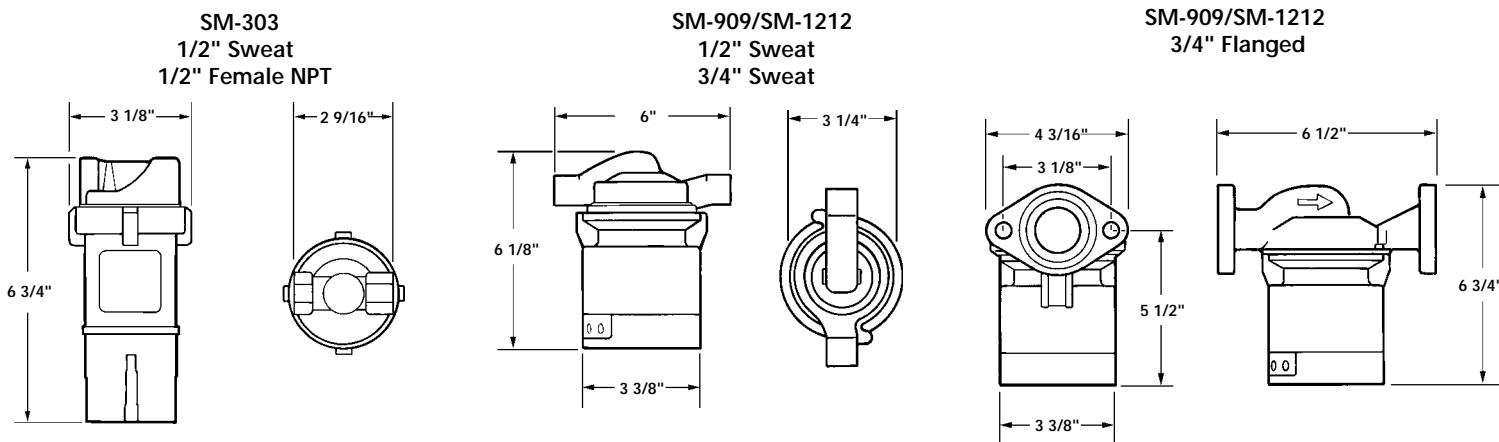

Specifications

Model No.	HP	Inlet/Outlet	Volts	F.L. Amps	Max. Fluid Temp.	Max. Line Pressure	Weight (Lbs.)
SM-303-BS 1/2	1/150	1/2" Sweat	115V	0.3	230°F	150 PSI	2.0
SM-303-BT 1/2	1/150	1/2" Female NPT	115	0.3	230°F	150	2.0
SM-909-BS 1/2-14	1/50	1/2" Sweat	115	0.6	230°	150	6.0
SM-909-BS 3/4-14	1/50	3/4" Sweat	115	0.6	230°	150	6.0
SM-909-BF-14	1/50	3/4" Flanged	115	0.6	230°	150	8.0
SM-909-BS-3/4	1/20	3/4" Sweat	115	0.9	230°	150	6.0
SM-909-BF	1/20	3/4" Flanged	115	0.9	230°	150	8.0
SM-909-BS 3/4-26	1/20	3/4" Sweat	115	0.9	230°	150	6.0
SM-909-BF-26	1/20	3/4" Flanged	115	0.9	230°	150	8.0
SM-1212-BS 3/4-26	1/15	3/4" Sweat	115	1.3	230°	150	6.0
SM-1212-BF 26	1/15	3/4" Flanged	115	1.3	230°	150	8.0

Centrifugal Canned Motor Pumps

Materials of Construction (*wetted parts*)

PART	MATERIAL
Pump Housing	Bronze
"O" Ring	EPDM
Impeller	Noryl (Polypropylene)
Bearing	Carbon Graphite/Ceramic
All Other Wetted Parts	316 Stainless Steel

Unpacking

When unpacking the unit inspect carefully for any damage that may have occurred during transit. Check for loose, damaged, or missing parts (see pump exploded view and replacement parts list). Do not attempt to assemble or operate pump if any parts are missing or damaged.

General Safety Information

1. Know the pump application, limitations and potential hazards.

⚠ WARNING *Pump should only be used with liquids compatible with pump component materials. Do not use to pump flammable or explosive fluids such as gasoline, fuel oil, kerosene, etc. Do not use in flammable and/or explosive atmospheres.*

For your protection always wear proper clothing, eye protection, etc. in case of any malfunction. For proper handling techniques and cautions, contact your chemical supplier, insurance company and local agencies (fire dept., etc.). Failure to comply with this warning could result in personal injury and/or property damage.

2. Make certain that the power source conforms to the requirements of your equipment.
3. Disconnect power before servicing. If the power disconnect is out of sight lock in the open position and tag it to prevent unexpected application of power. Failure to do so could

4. result in fatal electric shock!
4. Release all pressure within the system before servicing any component.
5. Drain liquids from the system before servicing.
6. **Personal Safety**
 - a. Wear safety glasses at all times when working with pumps.
 - b. Wear a face shield and proper apparel when pumping hazardous chemicals.
 - c. Keep work area clean, uncluttered, and properly lighted. Replace all unused tools and equipment.
 - d. Keep visitors at a safe distance from the work area.
 - e. Make workshop childproof - with padlocks, master switches and by removing starter keys.
7. This unit is not waterproof and is not intended to be used in showers, saunas, or others potentially wet locations. The motor is designed to be used in a clean dry location with access to an adequate supply of cooling air. Ambient temperature around the motor should not exceed 104° F (40°C). For out door installations motor must be protected by a cover that does not block airflow to and around the motor. This unit is not able to be submersed in water.
8. When wiring an electrically driven pump follow all electrical

and safety codes, as well as the most recent United States National Electrical Code (NEC) and the Occupational Safety and Health Act (OSHA).

9. Single phase motors: All units are supplied with 115 volt, single phase motors (unless otherwise noted) and provided with a 6 foot 3-wire flexible cord with 3-prong grounded plug suitable for a standard grounded type 115 volt receptacle. Where a 2-prong wall receptacle is encountered, it must be replaced with a properly grounded 3-prong receptacle installed in accordance with the National Electrical Code, local codes and ordinances. To ensure a proper ground, the grounding means must be tested by a qualified electrician.
10. Use only 3-wire extension cords that have 3-prong grounding type plugs and 3-pole receptacles that accept the equipment plug.
11. All wiring should be performed by a qualified electrician.
12. Protect electrical cord from sharp objects, hot surfaces, oil, and chemicals. Avoid kinking the cord. Replace or repair damaged or worn cords immediately.

⚠ WARNING *Do not handle a pump or pump motor with wet hands or when standing on a wet or damp surface or in water.*

Installation

WARNING *The pump should not be used in flammable or explosive atmospheres.*

In order to safely use this product, familiarize yourself with this pump and also with the liquid that is going to be pumped through the unit. This pump is not suitable for many liquids.

For installations where property damage might result from an inoperative or leaking pump due to power outages, discharge line blockage, or any other reason, a backup system(s) should be used.

Failure to follow any warning can result in personal injury and/or property damage.

1. Locate pump as close to the fluid source as possible, thus making the suction line as short and direct as possible.

CAUTION *The unit should be placed where the motor and electrical components are protected from the weather and humidity.*

2. Attach piping suction line to suction inlet and piping discharge line to discharge outlet. Avoid using looped section of pipe or fittings which might permit air to compromise airtight pipe connections.
3. Support the piping independently of the pump.
4. Laing circulators are lubricated by the pumped fluid. How they are mounted and the condition of the water in the system are important. **THOROUGHLY CLEAN** and **FLUSH** the system before installing the circulator. If the fluid contains a high level of dissolved solids such as dirt, sediment, or products of corrosion, a strainer and/or filter should be installed at least 12" before the inlet to the circulator.

Electrical

These instructions must be followed to reduce risk of electrical shock. All work should be performed by a qualified electrician and in accordance with the current national and local electrical codes and regulations. Consult the nameplate for electrical data. The motor is impedance protected.

Make certain that a properly sized circuit is available. Wire size should be based on the current carrying (amp) capacity of the conductor. The circulator must be grounded in accordance with the current national and local codes. Ground wire should be copper with current capacity at least equal to that of the wire carrying power to the circulator. Observe all minimum code requirements for your jurisdiction.

For circulators supplied with power cord, the current carrying capacity of the cord is suitable for proper operation. Make certain the receptacle is properly configured and in good working order. Check to make certain that the circuit is properly sized for the load.

Circulators intended for hardwire applications are supplied with 6" pigtailed of proper current carrying capacity and with a knockout in the motor end cap. Leads suitable for at least 194°F (90°C) should be used and connected to the pigtailed or directly to the terminals as indicated in the electrical compartment. Grounding wire should also be suitable for 194°F (90°C) and should be connected to the grounding terminal as indicated in the electrical compartment.

5. Isolation valves are recommended for both sides of the circulator. Valves should be positioned to avoid leakage onto the motor and electrical compartment. All elbows, tees, and sharp bends in the piping should be installed sufficiently upstream

or downstream of the suction and discharge ports. Avoid welding or soldering close to the circulator, which could cause damage to the unit.

Mounting

For installation purposes the arrows on the side of the pump housing indicate the direction of water flow through the circulator. Check to make sure the circulator is adequately supported and that neither the circulator nor the piping is severely stressed. Install the circulator at a point closest to the highest static pressure point, **but above the absolute lowest point** in the system to avoid dirt and sediment build-up. If required by application and code, install a safety relief valve to protect against over temperature and pressure. **Do not mount with the motor above the impeller.** This can cause the circulator to run dry leading to premature failure of the circulator which voids the warranty. **Refer to the figures below for proper orientation before installing the circulator.**



Correct Installation



Improper Installation - Do not mount in these orientations

PERFORMANCE CURVE:

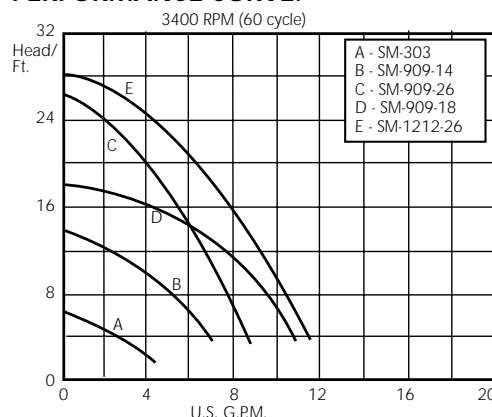

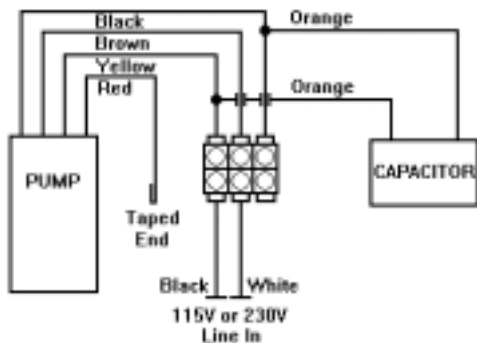

Figure 3 - Wiring Diagrams for SM-303 Models

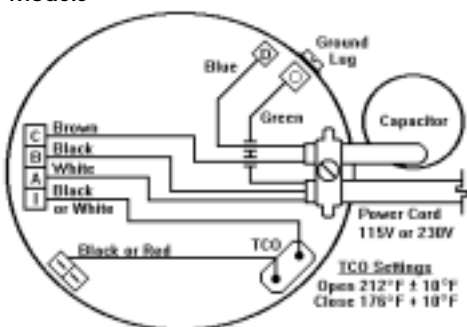

Figure 4 - Wiring Diagram for SM-909 and SM-1212 Models

Operation

1. Completely fill the system before operating the circulator. Do not start the circulator until the system has been filled. *Make sure the isolation valves are fully open and that there is water in the circulator.*
2. Purge air from the system prior to operating the circulator. ***These two steps are very important. The circulator should never be allowed to run dry. This can severely damage the circulator and will void the warranty.***
3. Operate the circulator for approximately 10 minutes to purge any remaining air in the system. It may be necessary to open a discharge valve, port and/or fixture to ensure that the air

has been purged. The circulator should be running quietly. If a "gurgling" noise is present it may mean there is still air in the system. Turning the circulator on and off several times will generally clear the remaining air. If this "gurgling" noise persists, recheck the system and re-purge the air. System and circulator should now operate quietly and efficiently.

subjected to freezing temperatures.

8. If provided, the suction line strainer should be cleaned at regular intervals.

Maintenance

⚠ WARNING *Make certain that the unit is disconnected from the power source before attempting to service or remove any components.*

1. Since the rotor/impeller unit (see exploded views) is the only moving part, its replacement and/or the replacement of the motor is simple to accomplish.
2. After the power has been disconnected remove the screws holding the pump housing to the motor (in the case of model SM-909 and SM-1212 units) or using a counter clockwise motion remove the screw ring housing to motor connection on model SM-303 units.
3. Remove the "O" ring from the pump housing.
4. Remove and replace the rotor. Check to make sure that the ceramic bearing on the motor is intact and is not chipped or otherwise damaged.
5. Replace the "O" ring with a new one and reverse the disassembly procedure to reassemble the pump.
6. Since these units are self lubricated by the pumped fluid, they never need external lubrication.
7. Pump should be drained when

Replacement Parts

Bronze Housing Models

Please provide the following information:

- Model number
- Serial number (if any)
- Part description

SM-303-B

SM-909-B and SM-1212-B

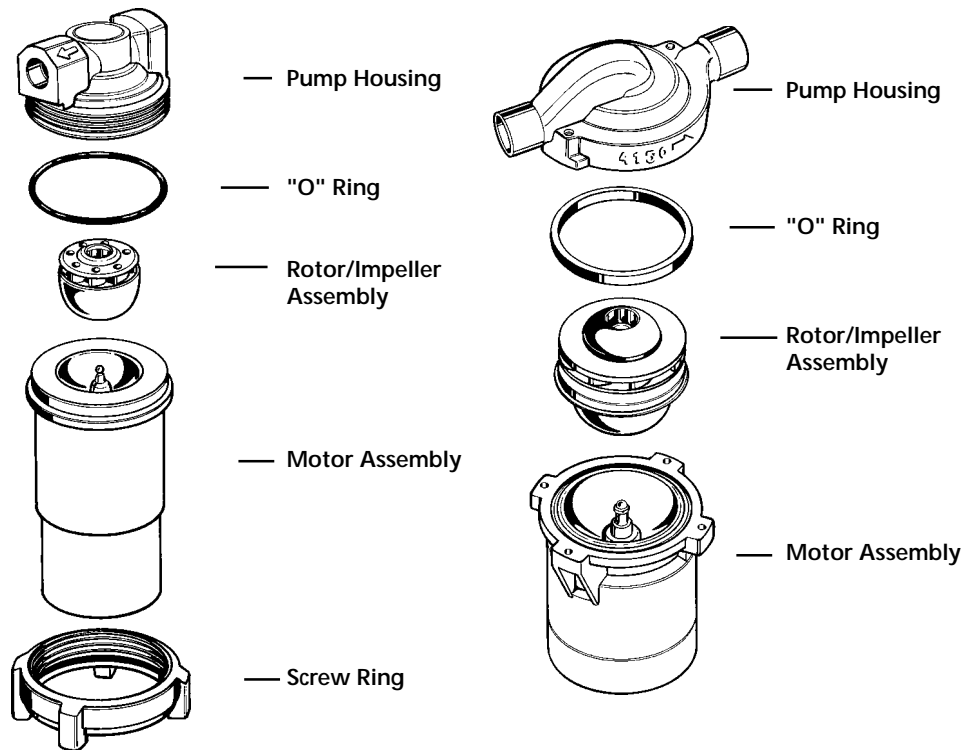

Trouble Shooting Chart

Symptom	Possible Causes	Corrective Action
Motor will not start or run	<ol style="list-style-type: none"> 1. Improperly wired 2. Blown fuse or open circuit breaker 3. Loose or broke wiring 4. Foreign object in impeller 5. Motor shorted out 6. Dry run cutout has opened circuit 	<ol style="list-style-type: none"> 1. Check motor wiring diagram 2. Replace fuse or circuit breaker after reason for overload has been corrected 3. Tighten connections, repair wiring 4. Disassemble pump, remove object 5. Replace motor 6. Allow unit to cool, restart after reason for cutout has been determined and corrected
Pump will not prime	<ol style="list-style-type: none"> 1. Leak, obstruction, or kink in suction line 2. Suction line closed 3. Pump is worn 	<ol style="list-style-type: none"> 1. Repair as necessary 2. Open 3. Replace parts
Little or no discharge	<ol style="list-style-type: none"> 1. Housing not filled with water 2. Suction piping too small 3. Total head too high 4. Impeller plugged 5. Pump not running 	<ol style="list-style-type: none"> 1. Properly prime housing 2. Increase to pump inlet size or one size larger 3. Reduce discharge head 4. Disassemble pump and clean impeller 5. Check motor operation
Noisy pump operation	<ol style="list-style-type: none"> 1. Air trapped in housing 2. Rotor bearing worn 3. Debris in housing 	<ol style="list-style-type: none"> 1. Check pump prime, also turn pump on and off several times to bump air pocket out of pump 2. Replace rotor assembly 3. Disassemble pump and remove debris

Laing Warranty

LAING THERMOTECH, INC. (LAING) warrants that LAING Products shall be free from defects in materials and workmanship for a period of twenty four (24) months from the date of manufacture. All LAING Product returned under warranty will be fully inspected to determine CAUSE OF FAILURE before any warranty repair or replacement is approved.

This warranty is void if the Product is altered or modified in any way by any person other than LAING, or if the Product is not installed and used in accordance with LAING's instructions, or if the product has been subjected to misuse, abuse, or neglect, including corrosion or wear caused by chemical action. The component materials set forth in a proposal and/or the specifications of an order, are recommended by LAING for the particular application, but such recommendations shall not be construed as a warranty against wear and/or corrosion; and, such recommendations are subject in all cases to verification and acceptance by the Buyer and/or User. This warranty is void if the label or other identifying marks have been altered, defaced, or removed.

LAING's liability under this warranty shall be limited to the repair and/or replacement, at LAING's sole discretion, of any Product or part thereof, without charge, F.O.B. LAING Factory. It is expressly understood and agreed that LAING shall not be liable or responsible for any costs incurred for labor, services, transportation, or any other charges which may arise in connection with the removal of the Product and/or installation of repaired or replacement Product. LAING also shall not be liable for any injury, loss or damage, direct, incidental or consequential (including, but not limited to, incidental or consequential damages for lost profits, lost sales, injury to person or property, or other incidental or consequential loss) resulting from the use or the inability to use the Product, and the User agrees that no other remedy shall be available to it. The maximum liability under this warranty shall not exceed the LAING contract price of the Product.

In order to receive warranty consideration, the Product must be returned prepaid to the distributor from which it was originally purchased together with proof of purchase, reason for return, return date, and description of installation and operating conditions.

All Product returned to LAING Factory must comply with the following: (1) must have prior LAING Authorization and shipped under Return Material Authorization (RMA) number provided by LAING; (2) must be sent prepaid, and; (3) must be accompanied by warranty claim supporting documentation. No LAING Product will be accepted by LAING at Factory unless and until all of the above requirements are satisfied.

LAING's liability under this warranty shall be in lieu of all warranties of fitness and in lieu of all warranties of merchantability. Before using, the User shall determine the suitability of the Product for his intended use, and the user assumes all risk and liability whatsoever in connection therewith.

This LIMITED WARRANTY contains the entire warranty for the Products manufactured by LAING. No one is authorized to make any warranty of representation other than as described above, and Buyer and/or User may not rely on any other warranty or representation.

U.L. Caution

This pump has been tested using water only. It's suitability for use with liquids other than water is the end users responsibility.