

# H-25 Series

Up to 20 gpm (75.7/min)

## H-25 Specialized Designs



Hydra-Cell Slurry Duty pumps are specifically designed for abrasive slurry applications. See page 72 for complete specifications.



The H-25 Hydra-Cell can be equipped with welded flange pump heads for critical performance applications such as oil/gas installations and chemical process facilities. See page 64.



H-25 with brass pump head

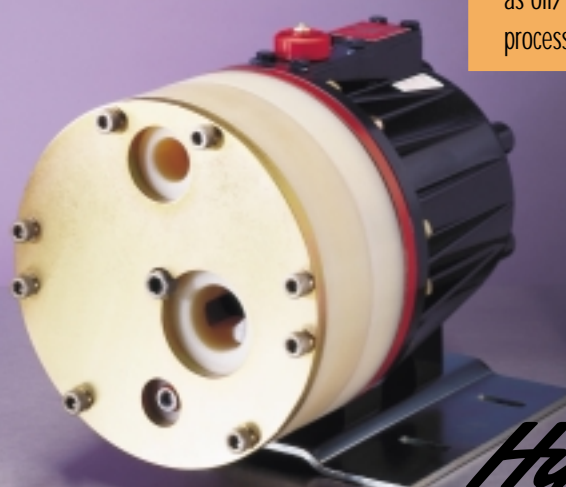

H-25 with polypropylene pump head

**Hydra-Cell**<sup>®</sup>  
SIMPLY BUILT TO LAST

# H-25 Series Performance

## flow

model	max flow		max input rpm
	gpm	l/min	
H-25-X	20	75.7	1050
H-25-E	20	75.7	1150
H-25-S	16	60.6	1150
H-25-I	12	45.4	1150

## pressure

### Maximum Inlet Pressure:

250 psi (17.3 bar)

### Pressure Variable To:

Metallic Heads: 1000 psi (69 bar)

Non-Metallic Heads: 250 psi (17.3 bar)

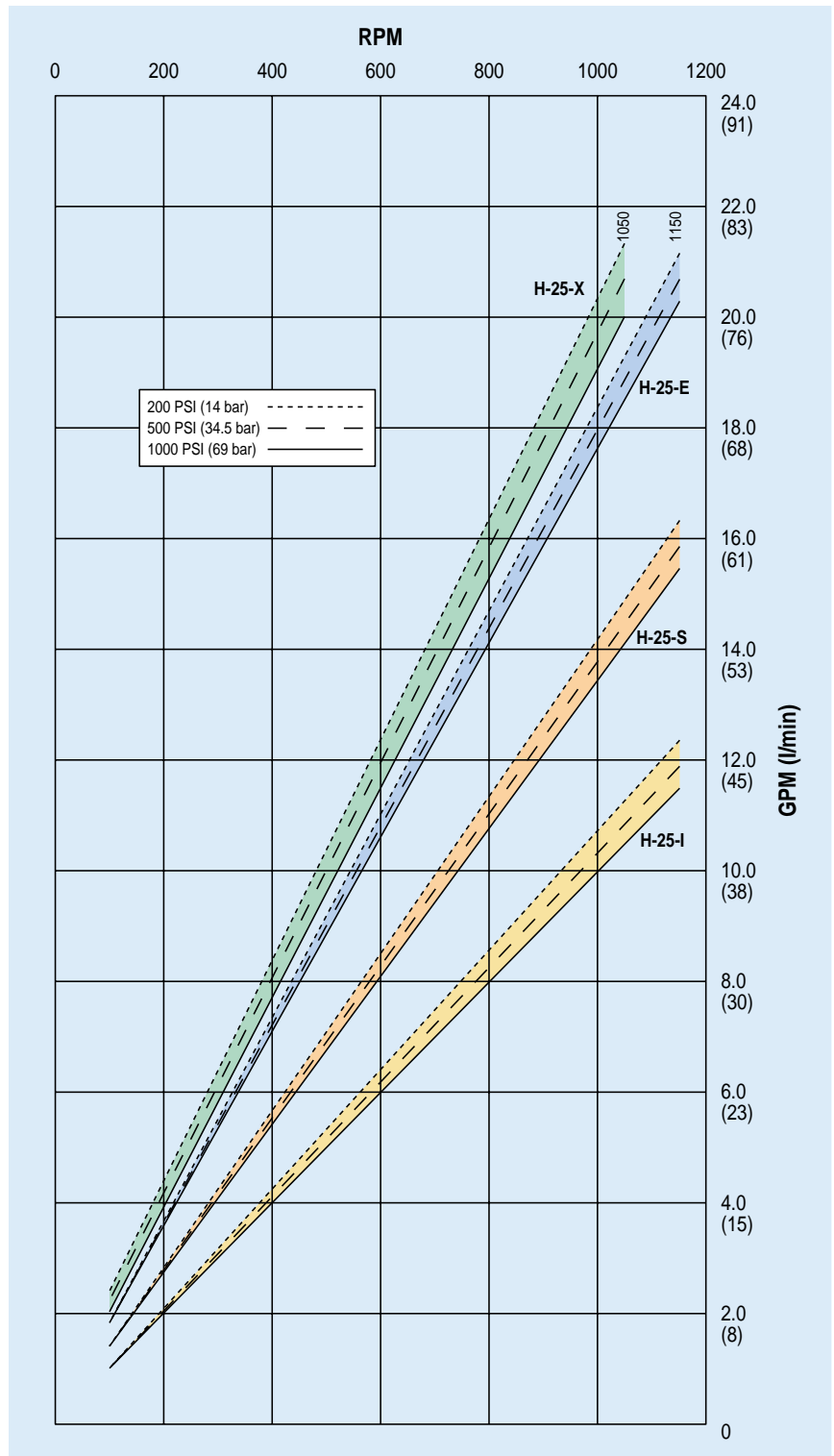

# H-25 Series Specifications

Maximum Capacity			
	rpm	gpm	l/min
H-25-X	1050	20	75.7
H-25-E	1150	20	75.7
H-25-S	1150	16	60.6
H-25-I	1150	12	45.4

Delivery @ max pressure		
	revs/gal	revs/liter
H-25-X	52	14
H-25-E	58	15
H-25-S	72	19
H-25-I	96	25

<b>Max Inlet Pressure</b>	250 psi (17.3 bar)
<b>Pressure Variable to</b>	
Metallic:	1000 psi (69 bar)
Non-Metallic:	250 psi (17.3 bar)
<b>Max Temperature</b>	250°F (refer to engineering section, page 94 for temperatures above 180°F)
<b>Inlet Port</b>	1-1/2 inch NPT
<b>Discharge Port</b>	1 inch NPT
<b>Shaft Diameter</b>	1-1/8 inch
<b>Shaft Rotation</b>	Bi-directional
<b>Bearings</b>	Tapered roller
<b>Oil Capacity</b>	2-1/2 US quarts (2.4 liters), see page 88 for oil selection and specification.
<b>Weight</b>	
Metallic Heads:	125 lbs (56.8 kg)
Non-Metallic Heads:	90 lbs (40.9 kg)

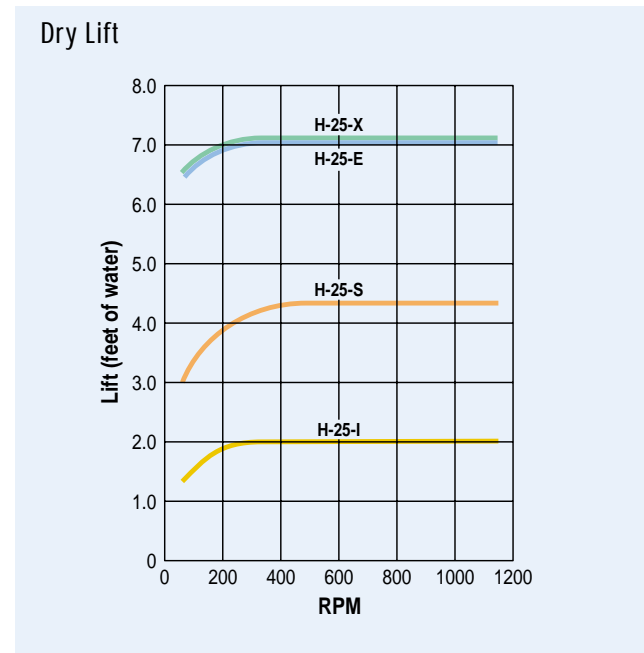
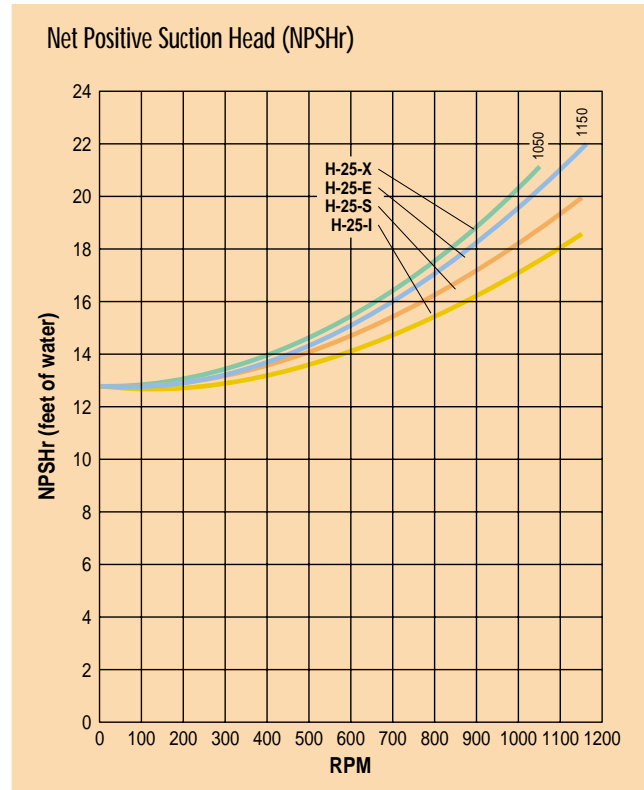

## Calculating Required Horsepower

$$\frac{50 \times \text{rpm}}{63,000} + \frac{\text{gpm} \times \text{psi}}{1,460} = \text{electric motor HP}$$

For installation guidelines and other pump selection design considerations, refer to pages 92-95.

# H-25 Series Dimensions

## H-25 Models with Metallic Pumping Head

Brass  
Cast Iron  
316 Stainless Steel  
Nickel Alloy (C Series)

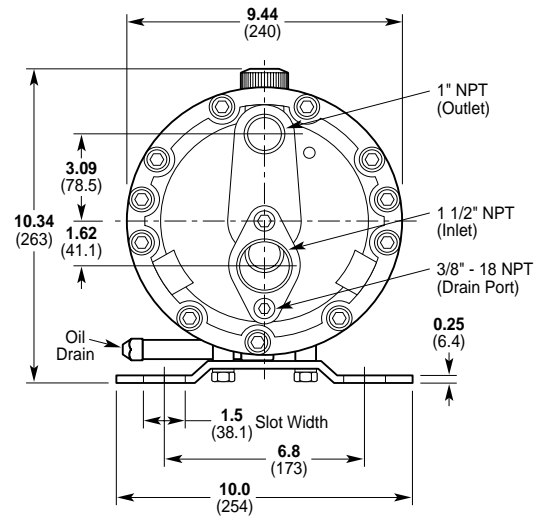
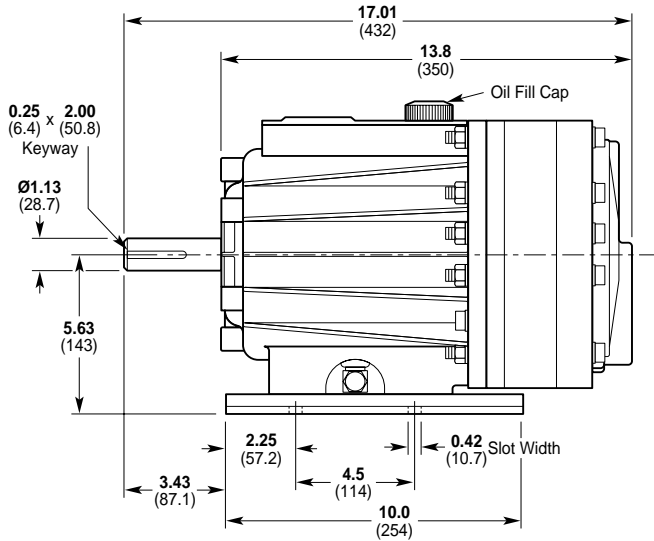

## H-25 Models with Non-metallic Pump Head

Kynar®  
Polypropylene

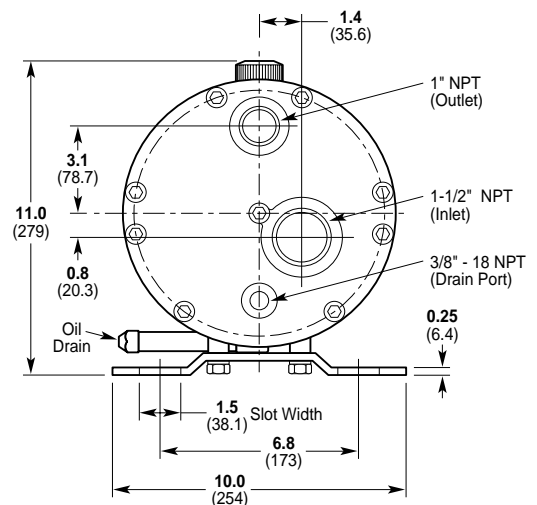
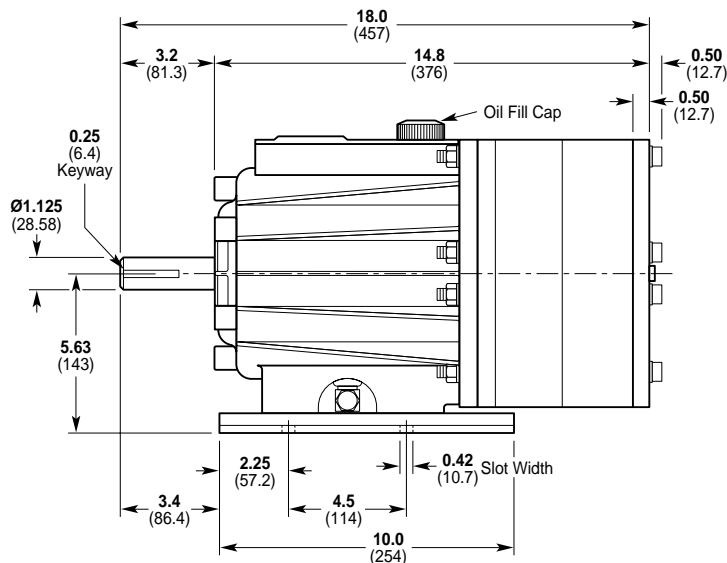

# H-25 Series Options

## Materials of Construction

H-25 Hydra-Cell pumps are manufactured in a variety of heavy-duty materials to meet specific pumping needs. Refer to the design section for more information on appropriate material selection and chemical compatibility. Other customized materials are available by special order. Contact factory application engineering department for further information.



### Pumping Head

316 Stainless Steel  
Brass  
Cast Iron  
Kynar®  
Nickel Alloy (Hastelloy Remelt, CMW12D)  
Polypropylene



### Valves

17-4 PH Stainless Steel  
Ceramic  
Hastelloy® C  
Nitronic 50



### Diaphragms & O-rings

Buna-N  
Buna-N-XS  
EPDM  
Neoprene  
Teflon®  
Viton®  
Viton®-XT



### Valve Springs

17-7 PH Stainless Steel  
Elgiloy®  
Hastelloy® C



### Valve Seats

17-4 PH Stainless Steel  
Ceramic  
Hastelloy® C  
Nitronic 50



### Valve Spring Retainers

17-7 PH Stainless Steel  
Celcon®  
Hastelloy® C  
Kynar®  
Nylon (Zytel®)  
Polypropylene

# H-25 Series Accessories

## Options, Accessories and Custom Designs

- Valves, page 78
- Hydra-Oil, page 88
- Couplers, page 87
- Hose Connectors, page 87
- Tool Kits, page 90



## Welded Flange Pump Heads

The H-25 Hydra-Cell can be equipped with welded flange pump heads for critical performance applications such as oil/gas installations and chemical process facilities.



### Design Features

- 316 stainless steel flanges
- Ductile iron pump housing
- 1-1/2" ANSI pipe flange inlet; 1" ANSI pipe flange outlet

### Ordering Information

Contact factory for complete specifications and ordering information.

# H-25 Series How To Order

## Ordering Information

A complete H-25 Series Model Number contains 12 digits including 8 customer-specified design options: for example H25XFBNHFECA.

1	2	3	4	5	6	7	8	9	10	11	12
H	2	5		F							

### 4 Hydraulic End Cam

- X Max 20 gpm (75.7 lpm) @ 1050 rpm
- E Max 20 gpm (75.7 lpm) @ 1150 rpm
- S Max 16 gpm (60.6 lpm) @ 1150 rpm
- I Max 12 gpm (45.4 lpm) @ 1150 rpm

### 6 Pumping Head Material

- B Brass
- C Cast Iron (nickel plated)
- M Kynar® (with Hastelloy® C followers & follower screws)
- N Polypropylene (with Hastelloy® C followers & follower screws)
- P Polypropylene (with 316 stainless steel followers & follower screws)
- S 316 Stainless Steel
- T Nickel Alloy (Hastelloy Remelt, CMW12D)

### 7 Diaphragm & O-ring Material

- E EPDM (requires 30 or 40 wt EPDM-compatible hydraulic end oil)
- G Viton®-XT
- J Teflon® (available with E and S cams only; 1050 rpm max; cannot be used with non-metallic heads)
- N Buna-N
- P Neoprene
- T Buna-N-XS
- V Viton®

### 8 Valve Seat Material

- C Ceramic
- H 17-4 PH Stainless Steel
- N Nitronic 50
- T Hastelloy® C

### 9 Valve Material

- C Ceramic
- F 17-4 PH Stainless Steel (machined)
- H 17-7 PH Stainless Steel (stamped)
- N Nitronic 50
- T Hastelloy® C

### 10 Valve Springs

- E Elgiloy®
- H 17-7 PH Stainless Steel
- T Hastelloy® C

### 11 Valve Spring Retainers

- C Celcon
- H 17-7 PH Stainless Steel
- M Kynar®
- P Polypropylene
- T Hastelloy® C
- Y Nylon (Zytel)

### 12 Hydra-Oil

- A 10W30 (standard)
- B 40-wt for continuous-duty (use with 316 SST or Hastelloy pump head (standard))
- C 30-wt EPDM-compatible oil
- D 40-wt high-temp EPDM-compatible oil
- E 30-wt food-contact oil
- F 40-wt high-temp food-contact oil
- G 5W30 cold-temp severe duty oil
- H 15W50 high-temp severe-duty synthetic oil