

## Magnetic Drive Pump



MDM is a wide ranging line of chemical process pumps designed to solve the most demanding chemical handling applications.

- **Unexpected dry running won't damage** the pump or interrupt the process. Our dry run (carbon/ceramic) design allows the pump to handle these situations with ease.
- **An expanded temperature range** (up to 300°F) as well as increased solids handling capabilities (up to 10%) provides users with solutions for their difficult applications.
- **Two materials of construction** and convenient mounting configurations allow MDM to handle many aggressive chemical and high purity applications.
- **Installation and maintenance time are reduced** with our compact, close-coupled design. Operating costs are reduced thanks to simple, modular construction and individually replaceable parts.
- **Small, lightweight and perfectly concentric magnet capsules** optimize pump efficiency. High strength rare earth magnets are totally encapsulated within fluoro-resin moldings.
- **MDM's back pullout design** allows the operator to inspect the pump while leaving the line pressurized. MDM's modular design keeps your operating cost low over the life of the pump by making regular maintenance and periodic inspection a snap.



## Model Code

**MDM - 1518 EKK 05 H XX**

- **Pump size (Suction x Discharge) and Motor HP**

<b>1516:</b>	1½ x 1	2/3 HP
<b>1518:</b>	1½ x 1	5/7.5/10 HP
<b>1518-2:</b>	1½ x 1	7.5/10/15/20/25 HP
<b>2156:</b>	2 x 1½	5/7.5/10 HP
<b>2158:</b>	2 x 1½	7.5/10/15/20/25 HP
<b>2526:</b>	2½ x 2	5/7.5/10 HP
<b>326:</b>	3 x 2	7.5/10/15/20/25 HP
- **Liquid End Construction**  
See Table
- **Motor size (Frame Size)**

<b>02:</b>	2HP	145 TC
<b>03:</b>	3 HP	182 TC
<b>05:</b>	5 HP	184 TC
<b>07:</b>	7 HP	213 TC
<b>10:</b>	10 HP	215 TC
<b>15:</b>	15 HP	254 TC
<b>20:</b>	20 HP	256 TC
<b>25:</b>	25 HP	284 TC
- **XX: Special design**  
Consult factory
- **H: High Temperature version**  
(1518-2 and 2158 only)

## Liquid End Construction

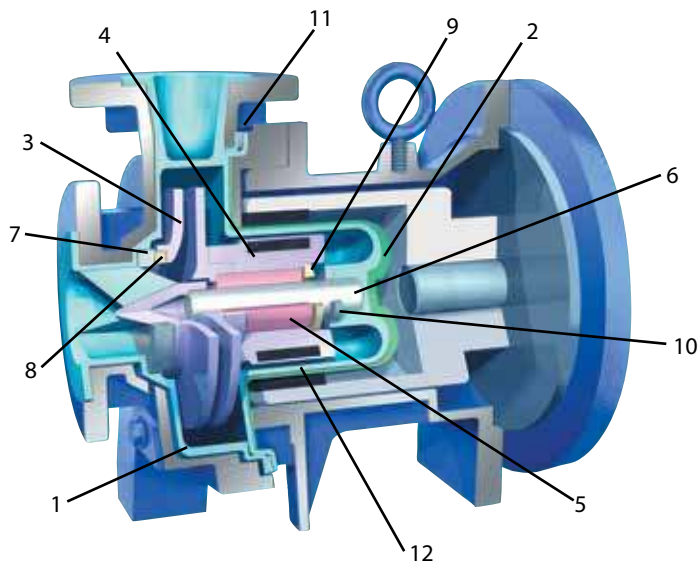

Materials	ECF*	EKK	PKK
1. Front casing	CFRETFE		100% PFA
2. Rear casing	CFRETFE		100% PFA
3. Impeller	CFRETFE		100% PFA
4. Inner magnet	CFRETFE		100% PFA
5. Bearing	High Density Carbon	SiC	SiC
6. Shaft	High Purity Alumina Ceramic	SiC	SiC
7. Outboard forward thrust collar	High Purity Alumina Ceramic	SiC	SiC
8. Inboard front thrust collar	PTFE	SiC	SiC
9. Inboard rear thrust collar	High Purity Alumina Ceramic	SiC	SiC
10. Outboard rear thrust collar	PTFE (with filler)		PTFE
11. Gasket	PTFE		
12. Support	For high temperature versions (1518-2 and 2158) only used on fluids 176°F (80°C) and above		

\* Dry-run rated construction

## Performance Curves

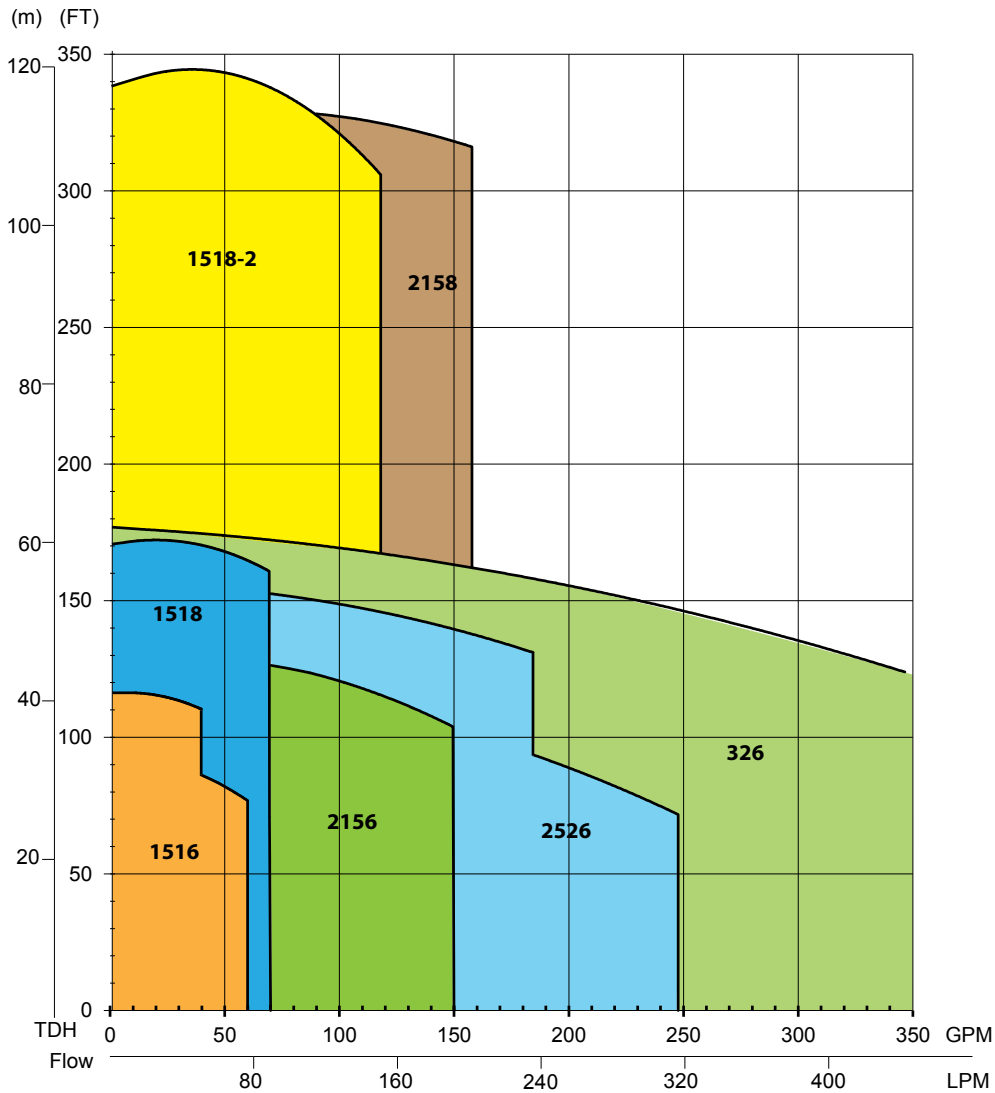

## Specifications

\*ANSI dimensional pump

Model	Connections Suction x Discharge 150#	Nominal Impeller Diameter	BEP Capacity @ 60Hz (GPM)	BEP Head (ft)	Minimum Flow Rate (GPM)	Nominal Motor (RPM)	Motor (HP)
1516*	1½" x 1"	5.52"	40	110'	5	3500	2 / 3
1518*	1½" x 1"	6.70"	70	159'	5	3500	5 / 7.5 / 10
1518-2*	1½" x 1"	8.86"	118	306'	13	3500	7.5 / 10 / 15 / 20 / 25
2156	2" x 1½"	5.71"	125	114'	13	3500	5 / 7.5 / 10
2158	2" x 1½"	8.86"	140	210'	13	3500	7.5 / 10 / 15 / 20 / 25
2526	2½" x 2"	6.30"	185	131'	13	3500	5 / 7.5 / 10
326*	3" x 2"	6.70"	247	150'	13	3500	7.5 / 10 / 15 / 20 / 25

## Liquid Temperature Range

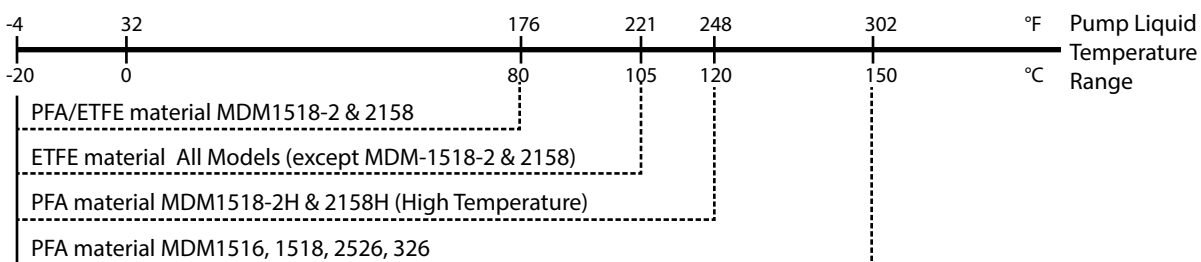

## Dimensions

### MDM 151X, 3 and 5 HP

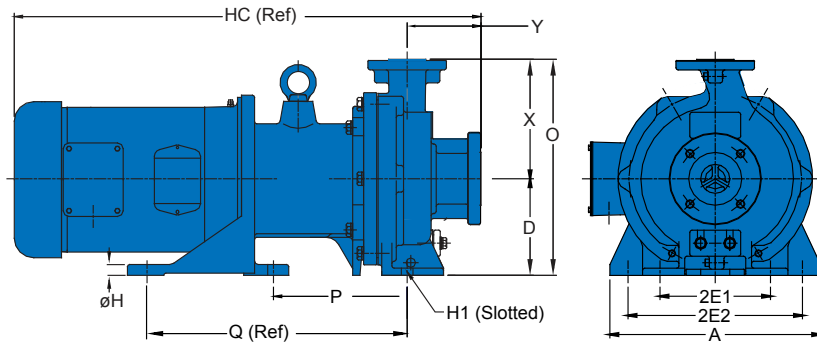

### MDM 326, 7.5-25 HP

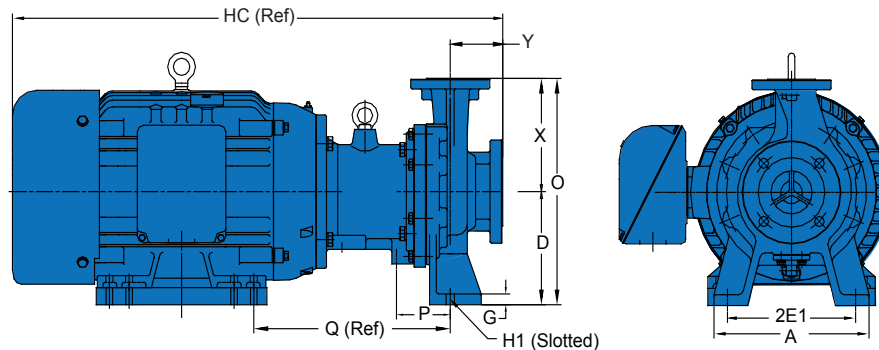

Inches (mm)

MDM Model	Frame	HC	D	2E1	2E2	A	Q	P	G	H	H1	O	X	Y	Weight w/o Motor
1516*	145TC	20.58 (523)	5.25 (133)	5.98 (152)	9.45 (240)	11.42 (290)	9.25 (235)	7.25 (184)	---	0.63 (16)	0.63 (16)	11.76 (299)	6.50 (165)	4.0 (102)	100 lbs
	182TC	29 (737)	5.25 (133)	5.98 (152)	9.45 (240)	7.87 (200)	14.09 (358)	7.25 (184)	---	0.63 (16)	0.63 (16)	11.76 (299)	6.50 (165)	4.0 (102)	100 lbs
1518*	184TC	30 (762)	5.25 (133)	5.98 (152)	9.45 (240)	7.87 (200)	14.09 (358)	7.25 (184)	---	0.63 (16)	0.63 (16)	11.76 (299)	6.50 (165)	4.0 (102)	132 lbs
	213-215TC	33.5 (851)	5.25 (133)	5.98 (152)	---	7.87 (200)	14.07 (357)	4.09 (104)	---	0.63 (16)	0.63 (16)	11.76 (299)	6.50 (165)	4.0 (102)	132 lbs
1518-2*	213-215TC	29.5 (749)	5.25 (133)	6.00 (152)	---	8.66 (220)	14.46 (367)	4.09 (104)	---	---	0.55 (14)	11.76 (299)	6.50 (165)	4.0 (102)	143 lbs
	254-256TC	33.5 (851)	6.25 (159)	6.00 (152)	---	9.84 (250)	14.97 (380)	4.09 (104)	---	---	0.55 (14)	12.75 (324)	6.50 (165)	4.0 (102)	154 lbs
	284TSC	37.35 (949)	7.00 (178)	6.00 (152)	---	9.84 (250)	14.97 (380)	4.09 (104)	0.75 (19)	---	0.55 (14)	13.50 (343)	6.50 (165)	4.0 (102)	154 lbs
2156	184TC	29 (737)	7.09 (180)	8.66 (220)	---	11.02 (280)	13.68 (348)	6.89 (175)	1.83 (47)	0.63 (16)	0.55 (14)	13.39 (340)	6.30 (160)	3.15 (80)	132 lbs
	213-215TC	31 (787)	7.09 (180)	8.66 (220)	11.02 (280)	11.02 (280)	14.45 (367)	3.70 (94)	3.54 (100)	0.55 (14)	0.38 (10)	13.39 (340)	6.30 (160)	3.15 (80)	132 lbs
2158	213-215TC	28.62 (727)	5.26 (134)	8.66 (220)	---	11.02 (280)	20.07 (510)	3.70 (94)	1.84 (47)	---	0.55 (14)	14.17 (360)	7.09 (180)	3.15 (80)	154 lbs
	254-256TC	32.67 (830)	7.09 (180)	8.66 (220)	---	11.02 (280)	19.57 (497)	3.70 (94)	0.84 (21)	---	0.55 (14)	14.17 (360)	7.09 (180)	3.15 (80)	165 lbs
	284TSC	36.5 (927)	7.09 (180)	8.66 (220)	---	11.02 (280)	20.27 (515)	3.58 (91)	---	---	0.55 (14)	14.17 (360)	7.09 (180)	3.15 (80)	165 lbs
2526	184TC	29 (737)	7.09 (180)	8.66 (220)	11.02 (280)	---	13.68 (348)	6.89 (175)	1.83 (47)	0.38 (10)	0.55 (14)	13.39 (340)	6.30 (160)	3.15 (80)	132 lbs
	213-215TC	31 (784)	7.09 (180)	8.66 (220)	11.02 (280)	---	14.45 (367)	3.70 (94)	3.54 (100)	0.55 (14)	0.38 (10)	13.39 (340)	6.30 (160)	3.15 (80)	132 lbs
326	213-215TC	31 (784)	8.25 (210)	9.76 (248)	---	11.81 (300)	14.47 (368)	4.09 (104)	2.99 (76)	0.63 (16)	---	16.50 (419)	8.25 (210)	4.0 (102)	144 lbs
	254-256TC	36 (914)	8.25 (210)	9.76 (248)	---	11.81 (300)	14.97 (380)	4.09 (104)	1.99 (76)	0.63 (16)	---	16.50 (419)	8.25 (210)	4.0 (102)	144 lbs
	284TSC	37.35 (949)	8.25 (210)	9.76 (248)	---	11.81 (300)	14.97 (380)	4.09 (104)	1.25 (32)	0.63 (16)	---	16.50 (419)	8.25 (210)	4.0 (102)	144 lbs

\*Meet ANSI B73 3M dimensional standards



IALT00042.G Nov 2013

[www.IwakiAmerica.com](http://www.IwakiAmerica.com)

