

## Magnetic Drive Pump



The MXM series design offers the best combination of durability, safety and performance for a wide range of chemical process applications.

- **Dry run capability** - With proven dry run capability and our unique self-radiating bearing lubrication circuit (PAT.) ,the MXM is able to withstand process-upset conditions. Heat dispersion holes located strategically behind the impeller facilitate removal of frictional bearing heat and improve bearing lubrication and cooling circuit flow under dry run or poor suction conditions.
- **Two piece rear casing design** - Offers improved pressure handling capability and a second barrier for improved safety. The front casing features injection-molded liner with guaranteed uniform thickness and is fully covered by a ductile cast iron cover for a combination of chemical resistance and mechanical integrity. All designs have ANSI 150# flanged connections.
- **Close-coupled back pull-out design** - Allows the operator to inspect the pump while leaving the line pressurized.
- **Dual end supported precision ground shafts** and balanced compact high strength Samarium Cobalt magnet capsule result in balanced lightweight inner magnet capsule assemblies optimizing torque transmission and pump efficiency. High strength rare earth magnets are totally encapsulated within fluororesin moldings.



## Pump identification

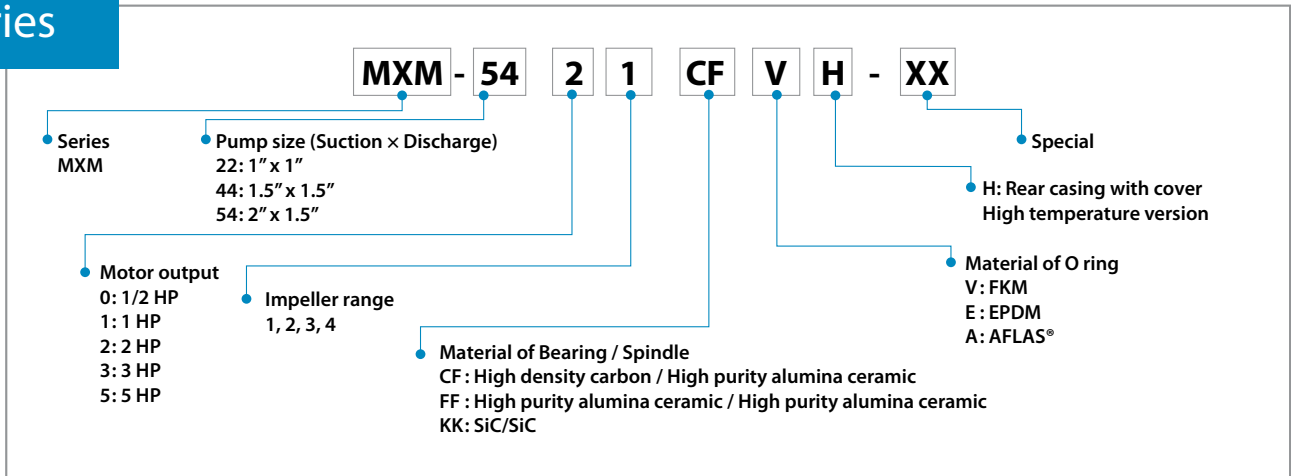

Ductile cast iron casing cover with 150# ANSI flanges with a separate precision injection removable molded casing liner provides the best combination of strength, corrosion resistance and serviceability.



Matched impellers and high strength magnets optimize performance and efficiency for your application. MXM models feature separate impellers and inner magnets maximizing the flexibility and application of the product.

Our two-piece rear casing design offers increased pressure resistance and inherent secondary containment in the event of damage to the primary internal rear casing. The unique shape of the rear casing also prevents stress concentration and improves the mechanical strength of the rear shaft support.



Utilizing the best materials for corrosion resistance and product integrity, the MXM features carbon fiber reinforced precision injection molded liquid contact parts with options of alumina ceramic, carbon or silicon carbide for bearings, shafts and thrust surfaces.



### Wet End Materials

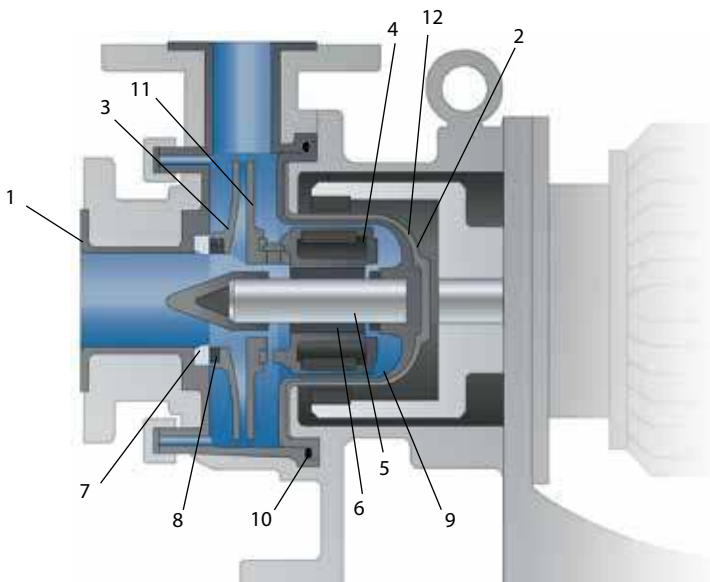

	Model:	CF	FF	KK
1	Front casing	CFRETFE		
2	Rear casing	CFRETFE		
3	Impeller	CFRETFE		
4	Magnet capsule	CFRETFE		
5	Spindle	High Purity Alumina Ceramic		SiC
6	Bearing	High Density Carbon	High Purity Alumina Ceramic	SiC
7	Liner ring	High Purity Alumina Ceramic		
8	Mouth ring	PTFE with filler		SiC
9	Rear thrust	CFRPFA		
10	O-ring	FKM/EPDM/AFLAS®		
11	Lock pin	CFRETFE		
12	Rear casing cover	FRP		

Performance Curves (see back page for MXM54 curves)

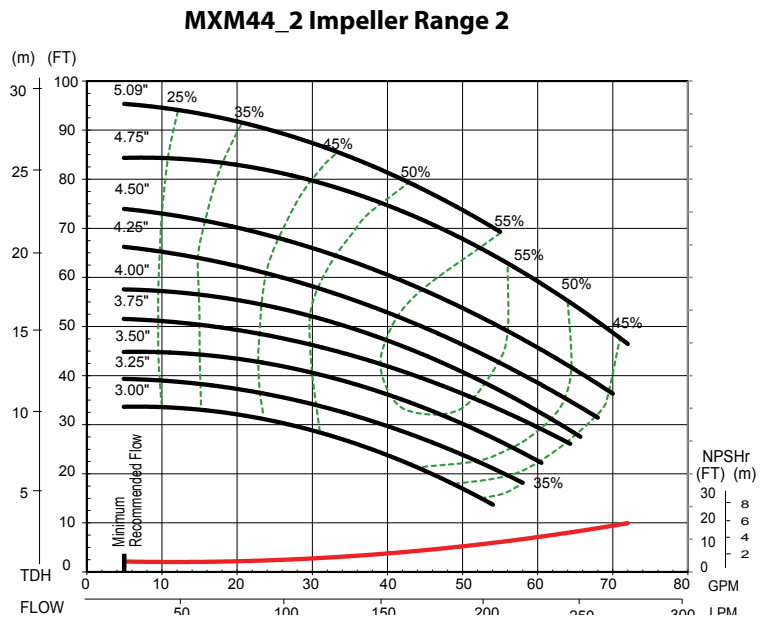
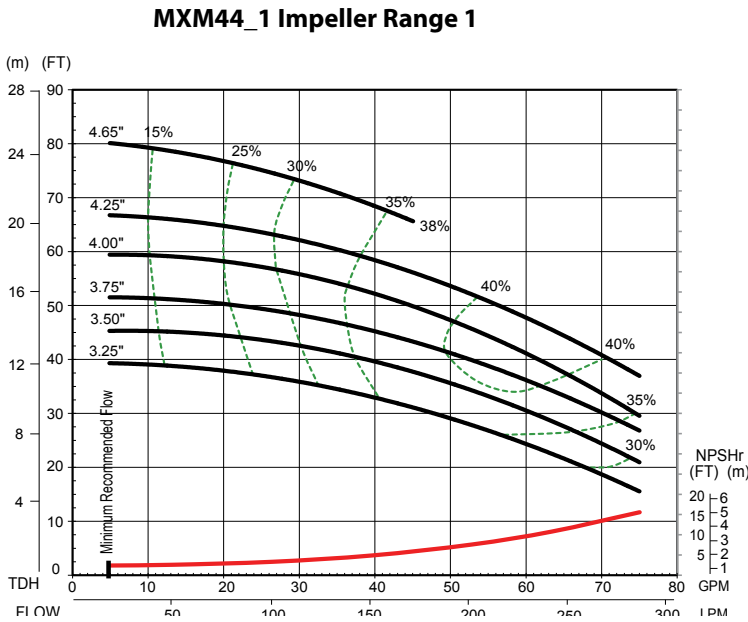
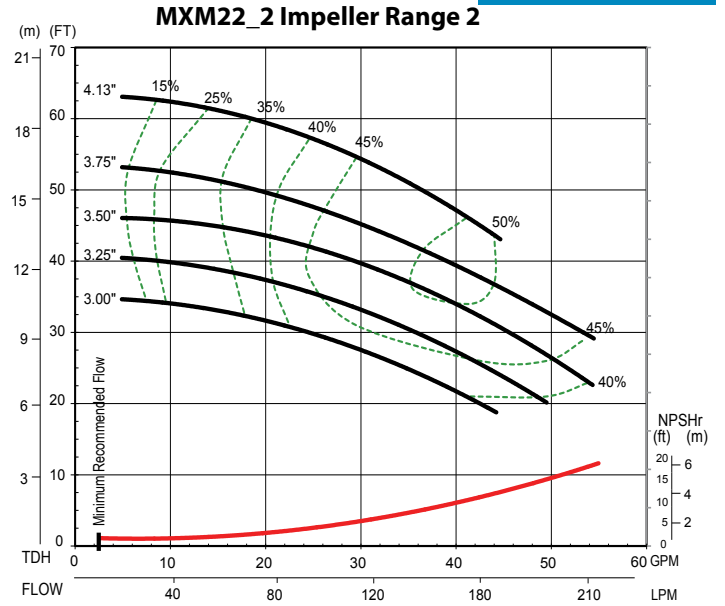
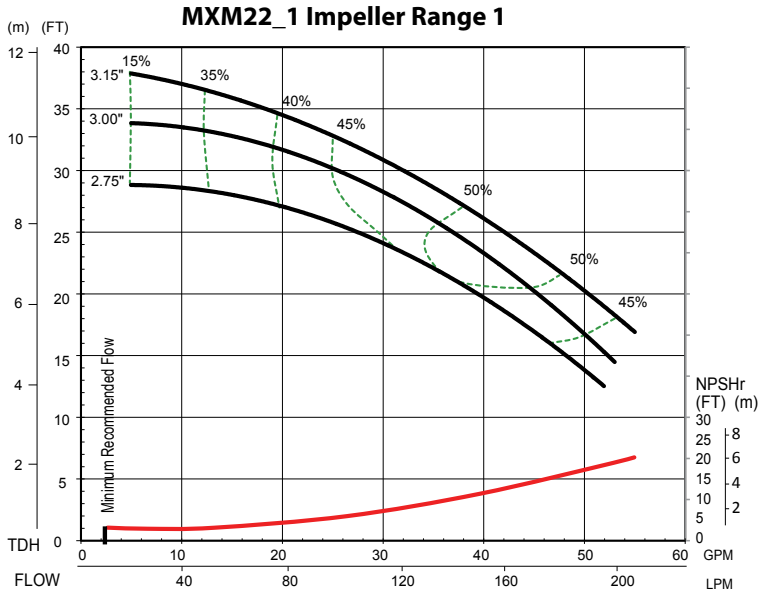

Specifications

Model	Connection Size Suction x Discharge	Minimum Flow	Maximum Head	Maximum Capacity	Motor/Frame	Pump Weight
MXM-221_	1.0\" x 1.0\" (25.4 mm x 25.4 mm)	2.5 GPM	38 Ft	55 GPM	½-¾ HP / 56C	45 lbs
MXM-222_		2.5 GPM	63 Ft	55 GPM	½-¾ HP / 56C	45 lbs
MXM-441_	1.5\" x 1.5\" (38.1 mm x 38.1 mm)	5.3 GPM	80 Ft	75 GPM	1 HP / 56C	55 lbs
MXM-442_		5.3 GPM	95 Ft	72 GPM	2 HP / 145 TC	60 lbs
MXM-542_	2.0\" x 1.5\" (50.8 mm x 38.1 mm)	5.3 GPM	96 Ft	115 GPM	2 HP / 145 TC	55 lbs
MXM-543_		5.3 GPM	122 Ft	160 GPM	3 HP / 182 TC	55 lbs
MXM-545_		13.2 GPM	142 Ft	160 GPM	5 HP / 184 TC	66 lbs

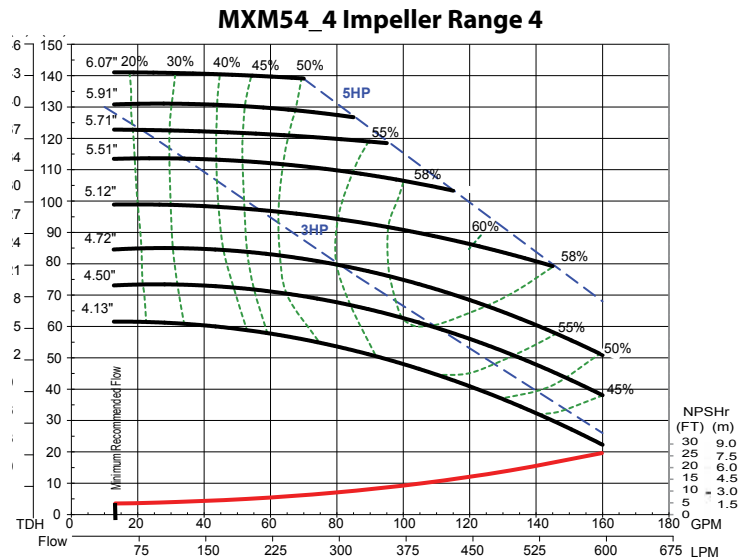
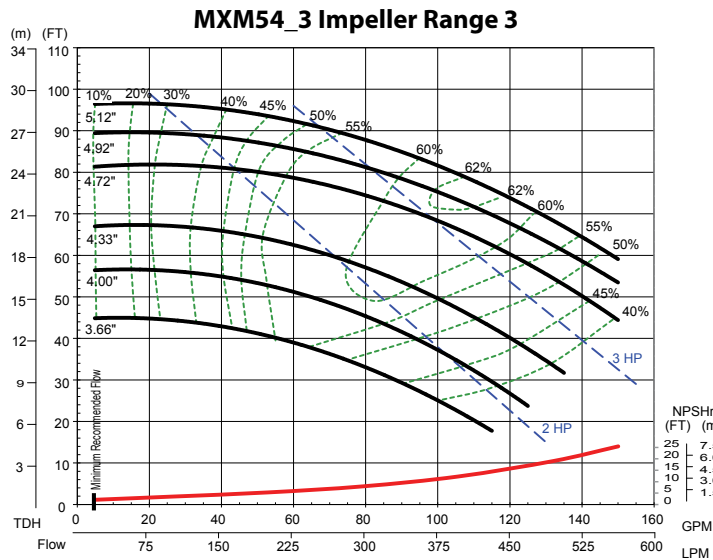
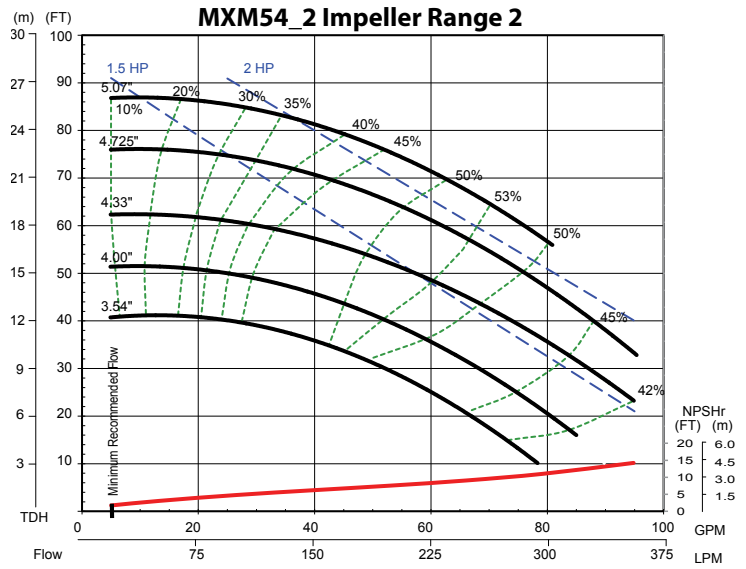
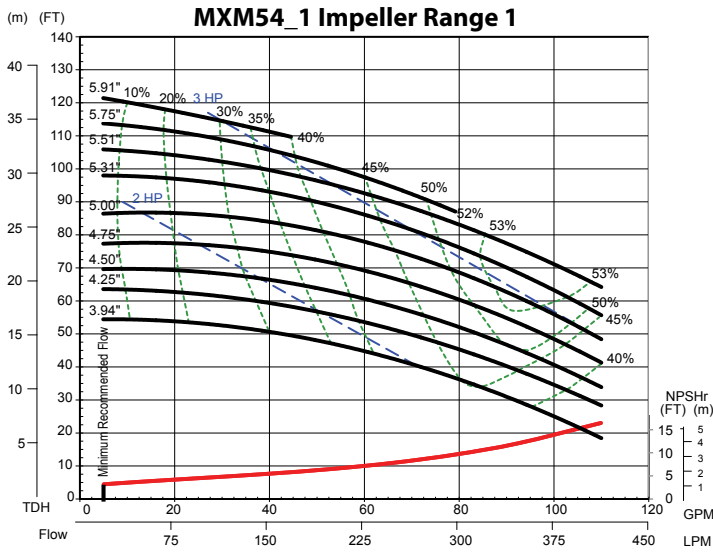

## Dimensions

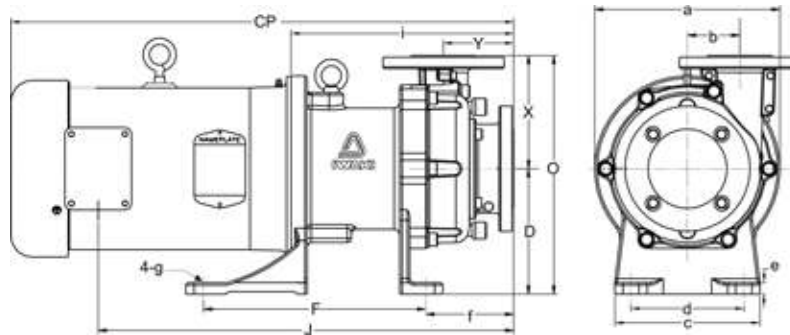

\* Varies according to motor manufacturer

Model	a	b	c	d	D	e	f	F	g	i	J	O	X	Y	CP*	
MXM-22(X)_	7.87 (199.9)	2.01 (51.1)	5.91 (150.1)	4.33 (109.9)	4.53 (115.1)	0.39 (9.9)	3.74 (95.0)	6.50 (165.1)	0.47 (11.9)	9.98 (253.5)	15.80 (401.3)	9.33 (237.0)	4.80 (121.9)	3.46 (87.9)	19.27 (489.5)	
MXM-441_	8.54 (216.9)	2.26 (57.4)	6.69 (169.9)	5.12 (130.0)	5.31 (134.9)	0.55 (14.0)	4.43 (112.5)	9.84 (249.9)	0.55 (14.0)	10.55 (268.0)	17.0 (431.8)	10.83 (275.1)	5.51 (140.0)	4.17 (105.9)	19.84 (503.9)	
MXM-442_											18.0 (457.2)				21.73 (551.9)	
MXM-542_	9.04 (229.6)	2.56 (65.0)	7.09 (180.1)	5.51 (140.0)	6.10 (154.9)	0.55 (14.0)	4.29 (109.0)	10.83 (275.1)	0.55 (14.0)	11.46 (291.8)	17.92 (455.2)	11.61 (294.9)	5.51 (140.0)	3.43 (87.1)	21.90 (556.3)	
MXM-543_											10.87 (276.1)				20.27 (514.9)	24.7 (627.4)
MXM-545_																



IALT00033.H Nov 2013

[www.IwakiAmerica.com](http://www.IwakiAmerica.com)

