

# Hydra·Cell<sup>®</sup>

## METERING SOLUTIONS™

### P300 Series

Maximum Flow Rate: 81.4 gph

Maximum Pressure: 2500 psi (172 bar) for Metallic Pump Heads

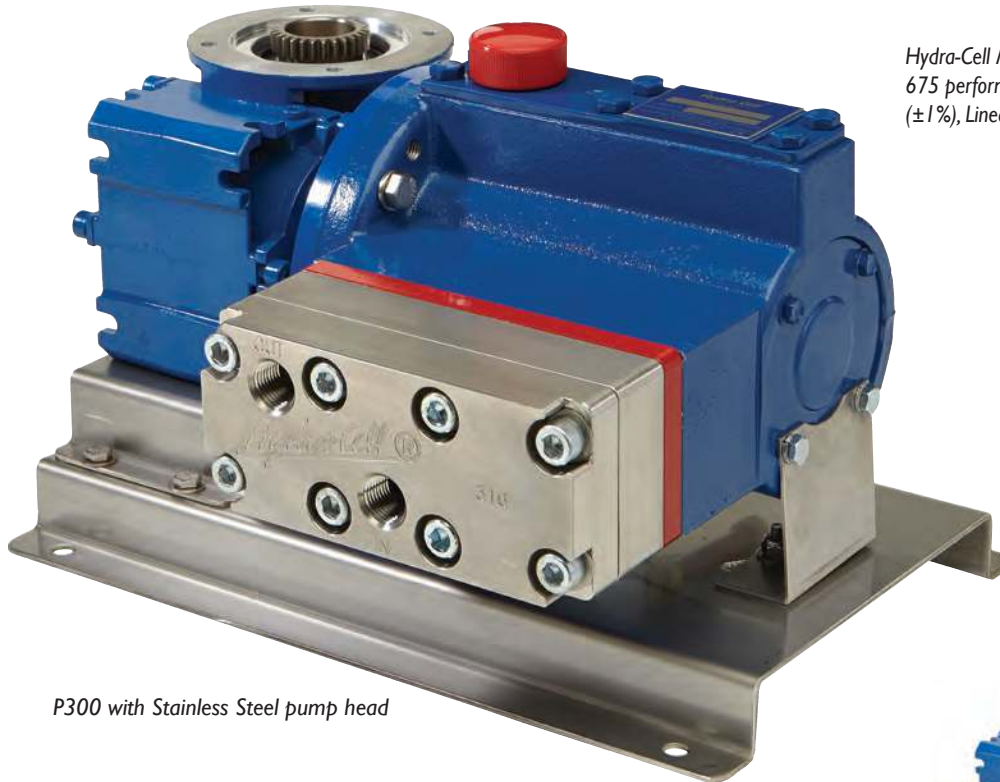

*P300 with Stainless Steel pump head*

Hydra-Cell Metering Solutions pumps meet or exceed API 675 performance standards for Steady-State Accuracy ( $\pm 1\%$ ), Linearity ( $\pm 3\%$ ), and Repeatability ( $\pm 3\%$ ).



*P300 with Brass pump head*

### Metering Pumps with “Pulse-Free” Linear Flow

- Handles a wide range of fluids from clear water to thick slurries
- Electronic flow control increases accuracy and reliability
- Smaller footprint saves valuable space
- One pump covers a wide range of flows and pressures - reducing inventory requirements with fast, simple field conversion
- Duplexing option doubles capacity and equipment savings
- Hydraulically-actuated, balanced diaphragms provide superior performance across entire pressure range
- Rugged construction with a variety of affordable choices for liquid end, diaphragm and check valve materials
- Seal-less design means no seals, cups, or packing to leak or replace
- A replenishment valve in every piston assembly ensures optimum actuating oil on every stroke for continuous accuracy

# P300 Series

## Performance Maximum Flow at Designated Pressure

100 psi	Metallic Pump Heads Only (gph)			Pump rpm	Gear Ratio	Motor rpm
	500 psi	1500 psi	2500 psi			
3.221	3.183	3.014	2.741	30	60:1	1800
3.895	3.849	3.655	3.350	36	50:1	
4.939	4.882	4.607	4.272	45	40:1	
6.639	6.548	6.194	5.786	60	30:1	
7.999	7.881	7.463	6.998	72	25:1	
10.04	9.880	9.368	8.815	90	20:1	
13.44	13.21	12.54	11.84	120	15:1	
20.24	19.88	18.89	17.90	180	10:1	
27.03	26.54	25.24	23.96	240	7.5:1	
40.63	39.87	37.93	36.08	360	5:1	
54.23	53.20	50.63	48.19	480	7.5:1	3600
81.42	79.85	76.02		720	5:1	

## Required Motor hp

1/4	1/2	3/4	1	1-1/2	2
-----	-----	-----	---	-------	---

## Pump Data

Diaphragms per Liquid End	3
Flow Control	Electronic variable speed drive
Maximum Discharge Pressure	
Metallic Heads:	2500 psi (172 bar)
Maximum Inlet Pressure	500 psi (34 bar)
Maximum Operating Temperature	
Metallic Heads:	250 °F (121 °C)*
Inlet Port	1/2 inch NPT or BSPT
Discharge Port	1/2 inch NPT or BSPT
Weight (less motor)**	
Metallic Heads:	54.5 lbs (24.7 kg)
Dimensions (less motor)**	
Metallic Heads:	15.79" W x 12.25" D x 9.46" H (401.2 mm W x 311.0 mm D x 240.2 mm H)

\* Consult factory for correct component selection for temperatures from 160 °F (71 °C) to 250 °F (121 °C).

\*\* For 56C motor frame only. Consult factory for other motor frame sizes.

## Representative Drawings Inches (mm)

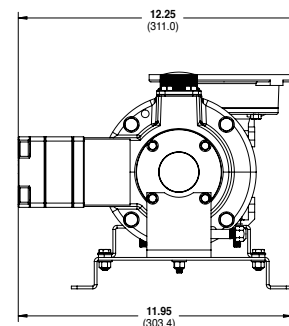
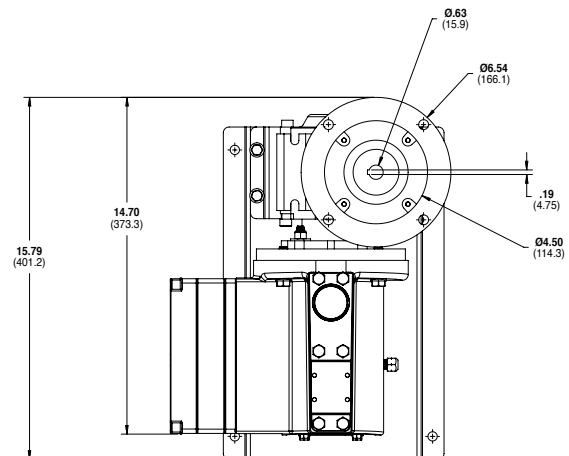

**Metallic Pump Heads**

# P300 Series

## How to Order

A complete pump order number contains 13 digits based on the specified pump materials listed below.

1	2	3	4	5	6	7	8	9	10	11	12	13
P	3	0	0									

### Pump Model Size (Digits 1-4)

**P300** For all P300 Pumps (Non Kel-Cell)

### Pump Version (Digit 5)

**N** NPT Ports (NEMA motors only)  
**M** BSPT Ports (IEC motors only)

### Pump Head / Retainer Material (Digit 6)

**B** Brass / Hastelloy C  
**R** 304 Stainless Steel / Hastelloy C  
**S** 316L Stainless Steel / Hastelloy C  
**T** Hastelloy C / Hastelloy C

### Diaphragm & O-ring Material / Oil (Digit 7)<sup>▲</sup>

**E** EPDM (EPDM-compatible oil)  
**X** FKM (Synthetic oil)  
**J** PTFE (Food-contact oil)  
**T** Buna-N (Synthetic oil)

<sup>▲</sup> See price list for different actuating oils available with these materials.

### Check Valve Material (Digits 8-9)

#### (Valve Spring / Valve Seat / Valve)

**SS** Elgiloy / Nitronic 50 / Nitronic 50  
**TT** Hastelloy C / Hastelloy C / Hastelloy C  
**SD** Elgiloy / Tungsten Carbide / Tungsten Carbide  
**TD** Hastelloy C / Tungsten Carbide / Tungsten Carbide

### Gearbox Ratio (Digits 10-12) NEMA Motors

<b>060</b>	60:1	(56C Motor Frame)
<b>050</b>	50:1	(56C Motor Frame)
<b>040</b>	40:1	(56C Motor Frame)
<b>030</b>	30:1	(56C Motor Frame)
<b>025</b>	25:1	(56C Motor Frame)
<b>020</b>	20:1	(56C Motor Frame)
<b>015</b>	15:1	(56C Motor Frame)
<b>010</b>	10:1	(56C Motor Frame)
<b>007</b>	7.5:1	(56C Motor Frame)
<b>A07</b>	7.5:1	(143/145TC Motor Frame)
<b>005</b>	5:1	(56C Motor Frame)
<b>A05</b>	5:1	(143/145TC Motor Frame)

### Base Plate (Digit 13)

**C** Carbon Steel (Epoxy painted)  
**S** 316L Stainless Steel

## Accessories, Options & Services

Consult the Hydra-Cell Metering Solutions catalog for complete details about available accessories and options as well as special services.

- Manifolds and Flanges
- Multiplexing Capability
- Different Gearbox Ratios
- Oil Systems and Kits
- Actuating Oils
- Motors (Standard/Explosion-proof)
- Controllers
- Control Freak Touch-screen Metering Controller
- SmartDrive Motor-Controller
- Calibration Cylinders
- Back Pressure Valves
- Pressure Relief Valves
- Pulsation Dampeners
- Demonstration (Cutaway) Units
- Testing Services
- System Components, Priming Kits and Plugs
- Replacement Part Kits and Tool Kits
- Customization Services



Hydra-Cell Metering Solutions demonstration unit complete with the Control Freak™ touch-screen metering controller.

# Hydra·Cell<sup>®</sup>

## METERING SOLUTIONS™

### **Wanner Engineering, Inc.**

#### **World Headquarters & Manufacturing**

Wanner Engineering, Inc.  
1204 Chestnut Avenue,  
Minneapolis, MN 55403 USA  
Phone: 612-332-5681 • Fax: 612-332-6937  
Toll-Free Fax (USA): 800-332-6812  
Email: [sales@wannereng.com](mailto:sales@wannereng.com)  
[www.Hydra-Cell.com](http://www.Hydra-Cell.com)

#### **Regional Office**

207 US Highway 281  
Wichita Falls, TX 76310 USA  
Phone: 940-322-7111  
Toll-Free: 800-234-1384  
Email: [sales@wannereng.com](mailto:sales@wannereng.com)  
[www.Hydra-Cell.com](http://www.Hydra-Cell.com)

#### **Latin American Office**

R. Álvaro Anes, 150 Bairro Campestre  
Santo André/São Paulo, Brazil - CEP 09070-030  
Phone: +55 (11) 4081-7098  
Email: [mmagoni@wannereng.com](mailto:mmagoni@wannereng.com)  
[www.Hydra-Cell.com](http://www.Hydra-Cell.com)

### **Wanner International Ltd.**

Wanner International, Ltd.  
Hampshire - United Kingdom  
Phone: +44 (0) 1252 816847  
Email: [sales@wannerint.com](mailto:sales@wannerint.com)  
[www.Hydra-Cell.eu](http://www.Hydra-Cell.eu)

### **Wanner Pumps Ltd.**

Wanner Pumps, Ltd.  
Kowloon - Hong Kong  
Phone: +852 3428 6534  
Email: [sales@wannerpumps.com](mailto:sales@wannerpumps.com)  
[www.WannerPumps.com](http://www.WannerPumps.com)

Shanghai - China  
Phone: +86-21-6876 3700  
Email: [sales@wannerpumps.com](mailto:sales@wannerpumps.com)  
[www.WannerPumps.com](http://www.WannerPumps.com)