

**Gardner**  
**Denver**

POSITIVE DISPLACEMENT BLOWER

# Conveying **Solutions**



It's all about...

# the BLEND

Your systems are not all the same—  
why should your blower be?



## SUTORBILT & SUTORBILT DSL

Bi-Lobe

Cool Air  
Large Air



## DUROFLOW

Solid Bi-Lobe

Heavy Duty  
Large Air

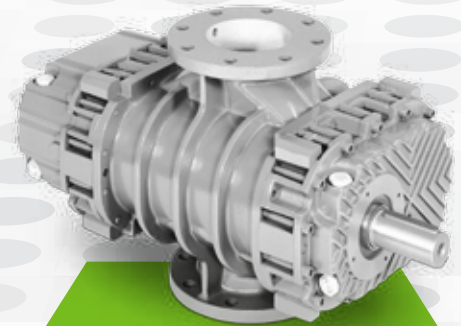

## RBS SERIES

Tri-Lobe

Heavy Duty  
Large Air

**GOOD**

**BET**

Gardner Denver has more blower technology styles than anyone else.

We can help you customize your system to meet your needs. More technology styles provides tailored options for you.



**HELIFLOW**

Twisted Tri-Lobe

Low Noise  
Heavy Duty  
Large Air



**CYCLOBLOWER**

Screw

Energy Savings  
Low Noise  
Heavy Duty  
Large Air



**CYCLOBLOWER H.E.**

Screw

Most Efficient  
High Pressure  
Low Noise  
Heavy Duty  
Large Air

**TER**

**BEST**

It's all about...

# the NETWORK





We're Where You Need Us

It's all about...

# the SIZING

QuickPik helps you customize our products to meet your demands.

Try it now!  
Scan the QR code or visit:  
[www.GDQuickPik.com](http://www.GDQuickPik.com)

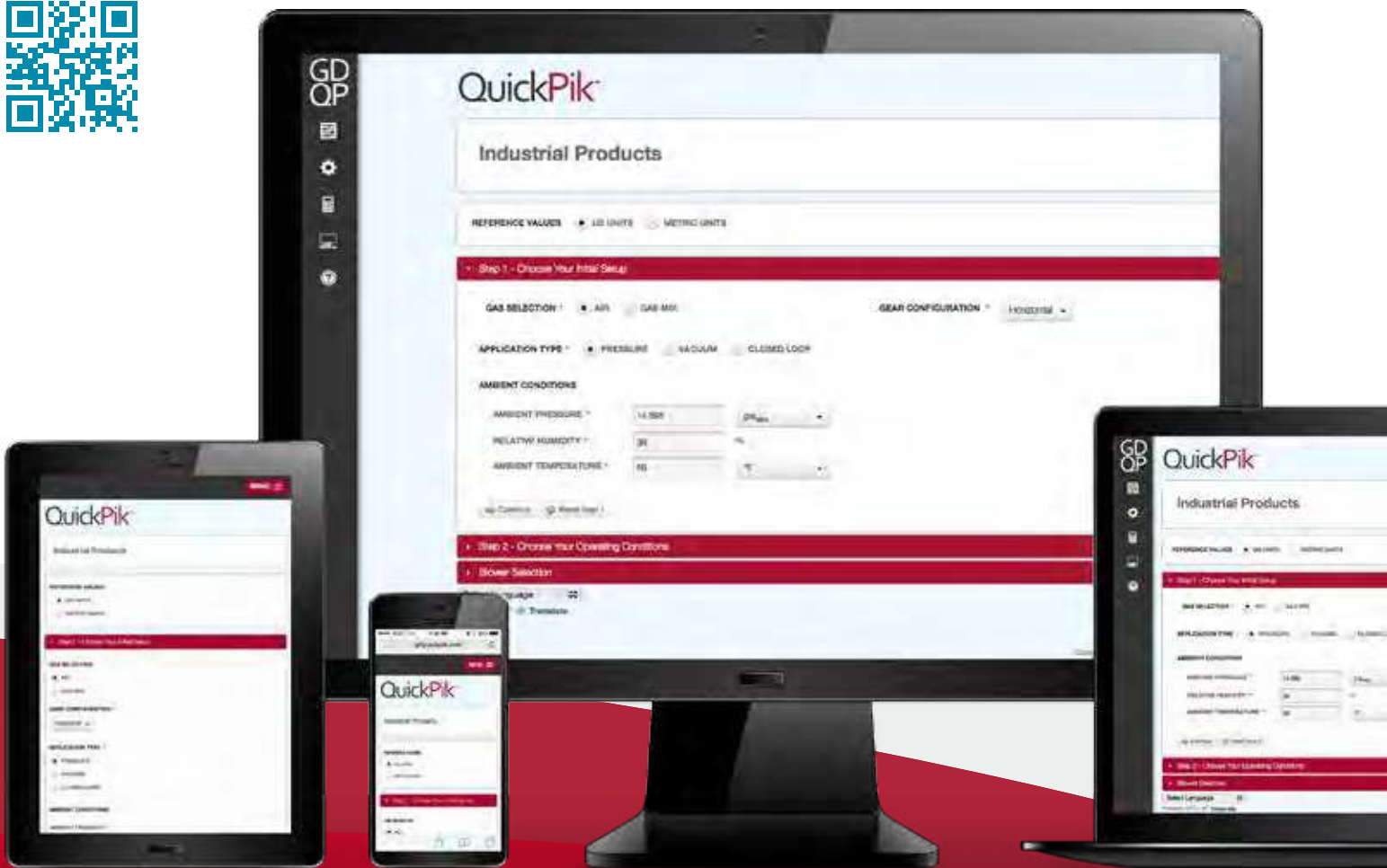

CycloBlower - 5CDL9

Download Performance Curves    Add a Database

Product Information

(ORIGINAL UNITS)

CONFIGURATIONS	FLOW ICFM	SPEED RPM	RPM % OF MAX	POWER HP	TEMP F	NOISE DBA	TEMP % OF MAX
Original	500	3545	71	38.8	194	87	55
Current	600	4254	71	30.8	194	87	55

(ENGLISH UNITS)

CONFIGURATIONS	FLOW ICFM	SPEED RPM	RPM % OF MAX	POWER HP	TEMP F	NOISE DBA	TEMP % OF MAX
Original	500	3545	71	38.8	194	87	55
Current	600	4254	71	30.8	194	87	55

(SI UNITS)

CONFIGURATIONS	FLOW M <sup>3</sup> /S	SPEED RPM	RPM % OF MAX	POWER KW	TEMP C	NOISE DBA	TEMP % OF MAX
Original	330	3545	71	28.4	88	87	55
Current	400	4254	71	22.8	88	87	55

Performance Curves

Temperature Rise



Comparison



PRODUCT	CycloBlower	Model 1	Model 2
FLOW (ICFM)	500	500	500
SPEED (RPM)	3545	3545	3545
RPM % OF MAX	71	87	71
POWER (HP)	38.8	30.8	38.8
TEMPERATURE (F)	194	194	194
NOISE (DBA)	87	87	87
TEMPERATURE % OF MAX	55	55	55

## Sizing Made Simple

- Accessible information at your fingertips
- Compare & contrast blowers
- Fit technology to your exact needs
- Mobile-friendly design for your laptop, tablet & phone
- Will work off-line
- Set up and customize your profile
- Save selections for future reference



It's all about...

# SAVING MONEY



## TOTAL COST OF BLOWER OWNERSHIP

- Energy
  - Maintenance
  - Investment
- Energy consumption is typically the largest cost of ownership
  - Save BIG with best-in-class energy efficiency
  - Lower your bottom line, increase your profits

INVEST WISELY  
REDUCE ENERGY

*Save Money*

## CYCLOBLOWER H.E. VS. STRAIGHT LOBE

BLOWER TECHNOLOGY	BHP USED @ 15 PSI	ENERGY COST PER YEAR
Standard Straight Lobe	163	\$106,695
CycloBlower H.E.	129	\$84,604

\*Calculations based on the cost of providing 2,000 cfm of air for 8760 hours (1 year of 24/7 operation) assuming motor drive efficiency of 90% and electricity cost of \$0.09/kWh.

**\$22,090**

ANNUAL SAVINGS





It's all about...

# HIGH PRESSURE

BRAKE HORSEPOWER REQUIREMENT COMPARISON  
at 2000 CFM

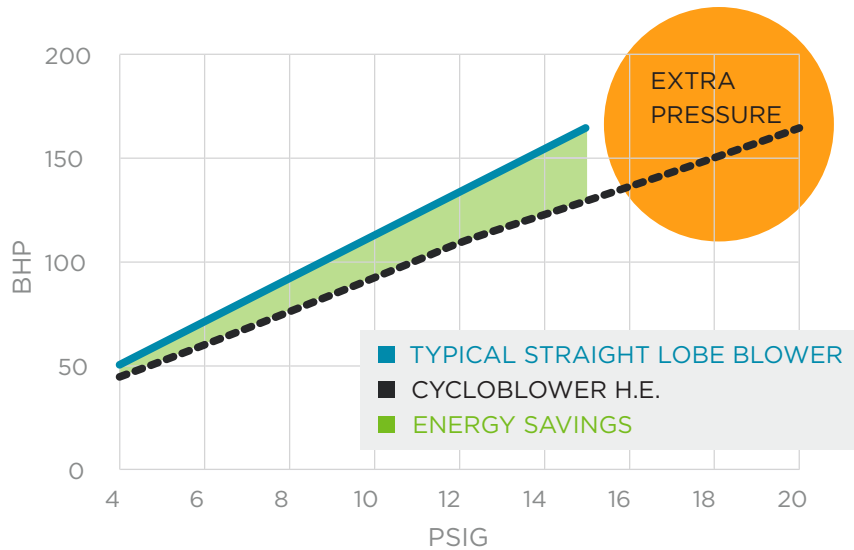

## Innovation Working for You!

- In many comparable applications, the CycloBlower operates more efficiently
- CycloBlower H.E. delivers higher pressure than other straight-lobe blowers
- Lower Horsepower = Lower Operating Costs
- Higher Pressure = New Conveying Possibilities

## The CycloBlower H.E.

- Can support dense phase conveying
- Oil-free compressed air
- Eliminates the need for traditional air compressors
- Best-in-class energy efficiency



It's all about...

# the LEGACY

## The ORIGINAL Rotary Screw Blower

A Reputation Earned by a Proven History of Quality, Reliability, and Performance

### CycloBlower: Unique Screw Design

- Decades of proven results
- Efficient, shock-free compression
- Dependable quality
- High capacity
- Energy savings made possible by screw design
- Ideal for continuous operation
- Can be used for dense phase applications
- Clean air/gas delivery
- Installation flexibility
- Low cost installation

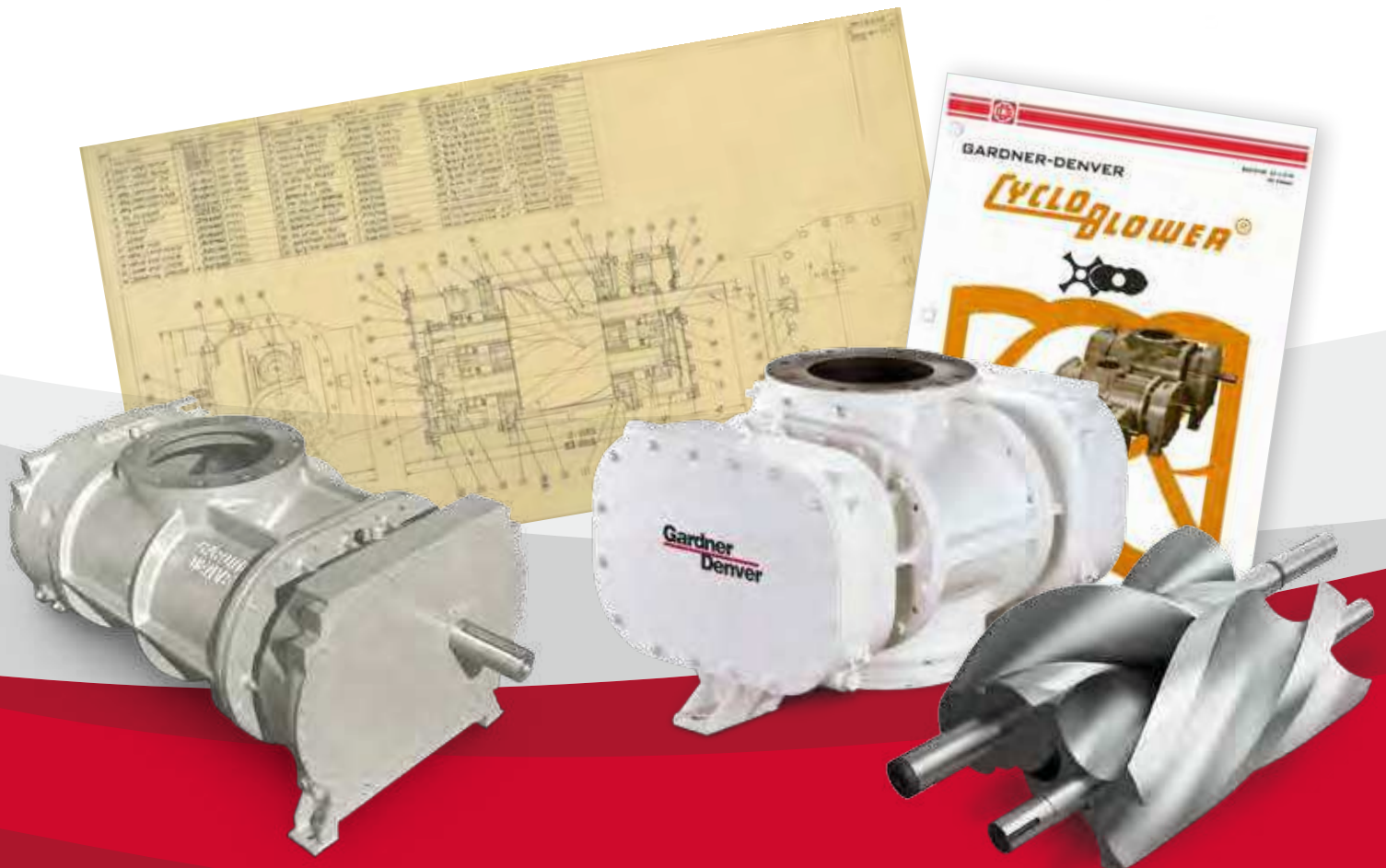



Experience Matters: Over 25,000  
CycloBlower Installations World-Wide

It's all about...

# the PULSE



Protect your ears,  
Protect your **WORKFORCE**



## CHANGE IN PRESSURE PULSE

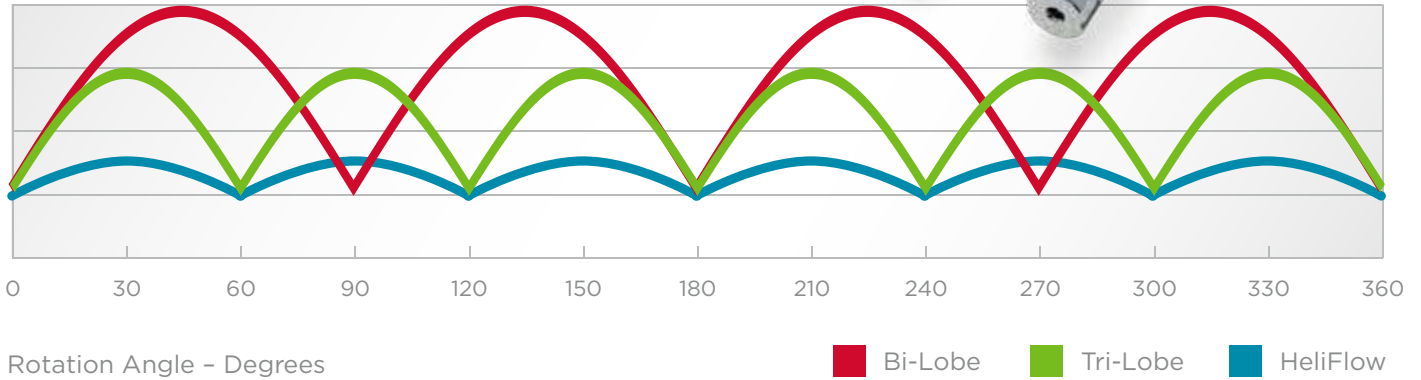

## The HeliFlow Series

REDUCED PULSE = LOWER NOISE = QUIETER OPERATION

### Lower Noise

Discharge pulsation is the chief contributor to high noise levels. HeliFlow provides the lowest pressure pulse in the lobe blower market. This reduces noise levels by 4-7 dBA over similar sized, straight-lobe blowers.

### Reduced Pulsations

HeliFlow provides more consistent flow variation, reducing the potential for damage to downstream valves and instrumentation.

### Higher Reliability

Discharge pressure pulsation causes axial thrust and higher variations in torque resulting in reduced bearing life. The HeliFlow smooth pulse operation extends the life of the blower.

BACKED BY A  
**2 YEAR**  
WARRANTY

From date of initial use or  
30 months from date of shipment



It's all about...

# the TRI-LOBE

Available in 29 Sizes

## The RBS Series Delivers

- Solid Tri-Lobe Rotors Offer Quiet, Efficient Operation
- Robust Design for Reliability
- Flexible Mounting Options for Easy Drop-in Replacement
- Dual Splash Lubrication
- 100,000 Hour Bearing Life
- Increased Efficiencies

## Options

- Stainless Steel Options
- High Vacuum Options
- Force Feed Lubrication
- Pre-Package Availability
- Special Seal Options

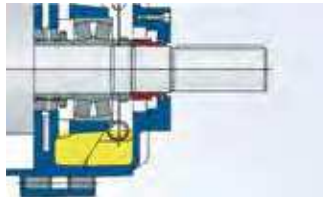

Single Mechanical Seal

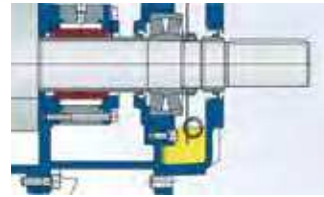

Double Mechanical Seal

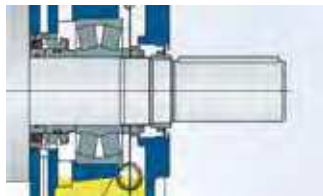

Lip Seal

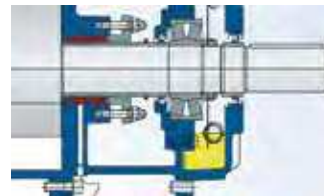

Gland Seal

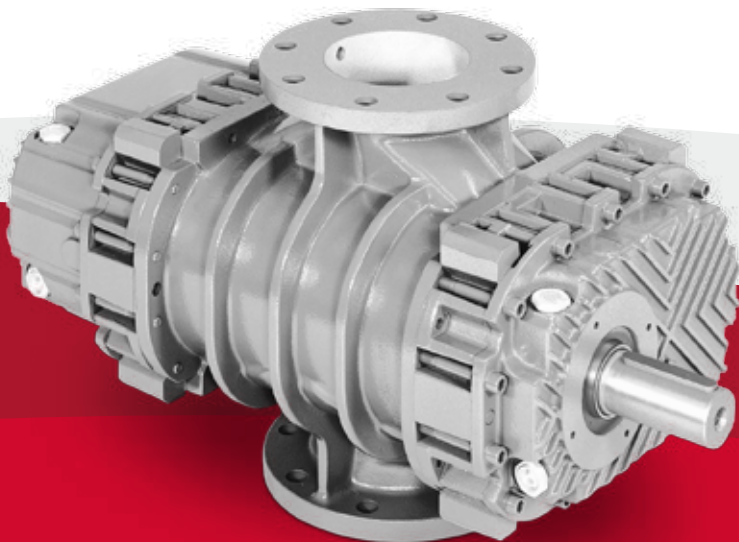

# Design Advantages

## Dual Splash Lubrication

Reliable dual splash lubrication on both the drive and gear ends for longer product life.

## Helical Gears

Helical timing gears for smooth and quiet operation at all speeds.

## Leak Free Operation

Piston rings and flinger maximize seal life in continuous severe duty applications.

## Durable Shafts

High strength shafts that allow higher operating pressures and rotation speeds.

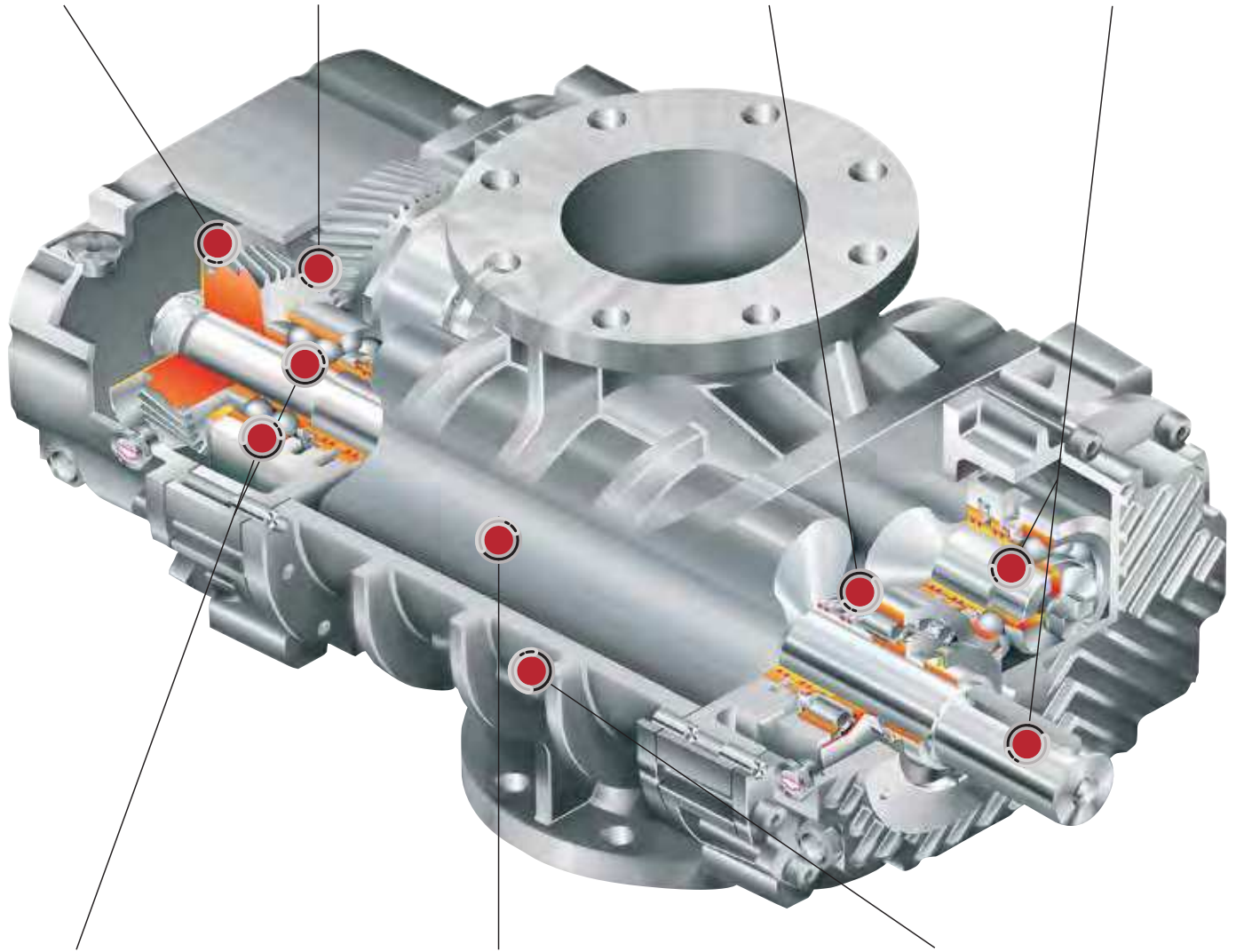

## Long Life Bearings

Reinforced roller bearings are calculated for a lifespan of 100,000 hours under the most severe operating conditions.

## Three-Lobe Rotors

Involute Three-Lobe Rotors offer the highest performances and efficiencies.

## Single Piece Cylinder

High strength impeller case is heavily ribbed and machined from a single piece of cast iron to retain internal clearances and improve heat dissipation.

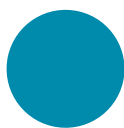
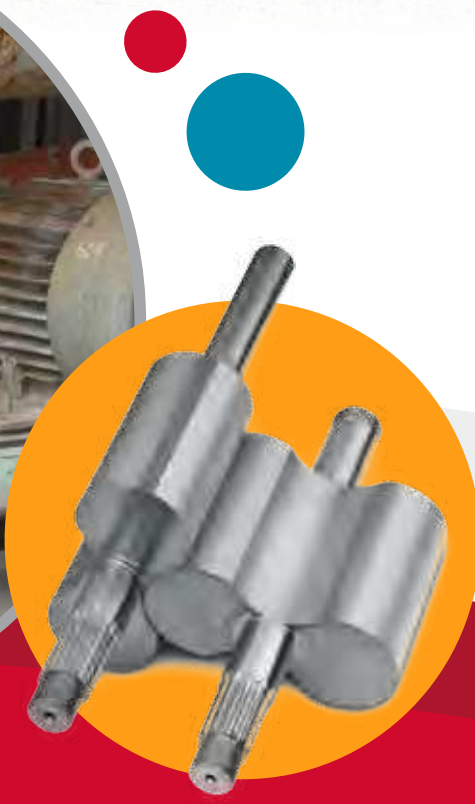



It's all about...

# TOUGHNESS

## Designed for Dusty, Abrasive Environments

- Single piece, high-strength rotor casting
- Oversized bearings
- Dual-splash lubrication
- Advanced oil and air seals
- ISO 9001 quality certified



Built for YOU, Built to LAST



It's all about...

# COOL AIR



Sutorbilt 8000 Series



Sutorbilt 4500 Series

Our blowers are designed to **run cooler & protect** your product



Sutorbilt Legend Series

## Hot Air Spoils Product

### Sutorbilt

- Coolest in its class
- The most versatile blower available
- Over 240 configuration options
- Grease- or dual-splash lubrication
- Quiet series option

For over 75 years, the Sutorbilt family of positive displacement blowers and vacuum pumps have been synonymous with quality and reliability. The Sutorbilt line is at the heart of an ever-expanding variety of air solutions working every minute of every day around the globe.



It's all about...

# the Complete Package

Gardner Denver has more blower package options than anyone else

We can help you customize your system to meet your needs. More technology designs provides tailored options for you.

- Smart Design
- Easy Maintenance
- Compact Installation
- Quiet Operation
- Enclosed or Unenclosed Available
- Inverter Duty Motors for VFD Capabilities

## IQ-RB

### SIMPLE

Straight Tri-Lobe

Pressure to 15 PSI

Vacuum to 15 inHg

5,500 Max CFM

3-500 HP

Fixed Speed

Mechanical Gauges



## IQ

### SMART

Twisted Tri-Lobe  
Pressure to 15 PSI  
Vacuum to 17 inHg  
1,500 max CFM  
7.5-100 HP  
Fixed Speed or VFD  
AirSmart Controller



## IQ-HE

### EFFICIENT

3x5 Helical Screw  
Pressure to 36 PSI  
5,625 Max CFM  
7.5-500 HP  
Fixed Speed  
AirSmart G2 Controller









Patented  
Rotor Profile  
High Efficiency  
up to 36 PSI

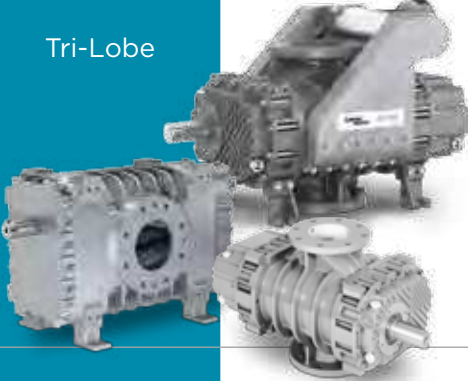
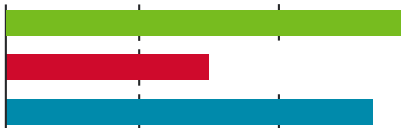

It's all about...

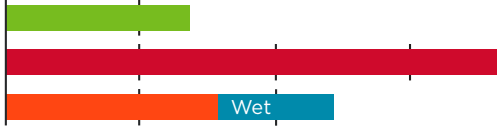
# the RANGE

Technology	Specifications		
<p>Bi-Lobe</p> 	<p>UP TO <b>26,000</b> CFM <b>15</b> PSI <b>24</b> inHg</p>	 <p>GD DuroFlow®, GD Sutorbilt®</p>	
<p>Tri-Lobe</p> 	<p>UP TO <b>14,570</b> CFM <b>15</b> PSI <b>27</b> inHg</p>	 <p>GD HeliFlow®, GD RBS</p>	
<p>Helical Screw</p> 	<p>UP TO <b>6,700</b> CFM <b>36</b> PSI <b>24</b> inHg</p>	 <p>GD CycloBlower®, GD CycloBlower® H.E.</p>	
<p>Blower Packages</p> 	<p>UP TO <b>5,625</b> CFM <b>36</b> PSI <b>17</b> inHg</p>	 <p>IQ, IQ-RB, IQ-HE</p>	



Dense & Dilute  
Phase Conveying  
**SOLUTIONS**

The leader in every market we serve  
by continuously improving all business processes  
with a focus on innovation and velocity

**Gardner**  
**Denver**<sup>®</sup>

**Gardner Denver, Inc.**

1800 Gardner Expressway  
Quincy, IL 62305  
866-428-4890

[www.gardnerdenver.com/gdproducts](http://www.gardnerdenver.com/gdproducts)



©2017 Gardner Denver, Inc. Printed in U.S.A.  
PD-APP-CONVEY 3rd Ed. 4/17

 Please recycle after use.