

**Gardner**  
**Denver**

POSITIVE DISPLACEMENT BLOWER

# Milling Solutions





Positive displacement blowers are an integral part of the milling industry. These blowers are most effective with high volumes at low vacuums and pressures.

Choosing the right blower is critical to **maximizing a mill's productivity** and return on investment (ROI)

**Your systems are not all the same, why should your blower be?**

Gardner Denver will make sure you are using the right blower for the job tailoring technologies to what is important to you. Millers have trusted Gardner Denver and its blowers to do the job decade after decade, with exceptional quality, selection and service before and after the sale.

It's all about...

# the Milling Industry



## Better Service

- Extensive distributor network
- Distributor network gives you local relationships, fast response and service
- Reliable and trusted distributors have factory-trained technicians
- Parts, lubricants and other operating supplies are available locally with training for operational personnel

## Better Quality

- More than 75 years blower manufacturing experience
- Recognized as global industry leader
- Focus on quality of every blower that we make—we set the standard
- Our history, experience and reputation set us apart from the competition
- Purchase a quality product backed by extensive warranties

## Better Selection

- More technology styles than anyone else in the industry
- Bi-lobe, Tri-lobe, Twisted Tri-lobe, and Helical Screw blowers
- Each technology provides unique solutions for your specific requirements
- We have the blower technology options to meet your exact needs

It's all about...

# the Network

We're where you need us

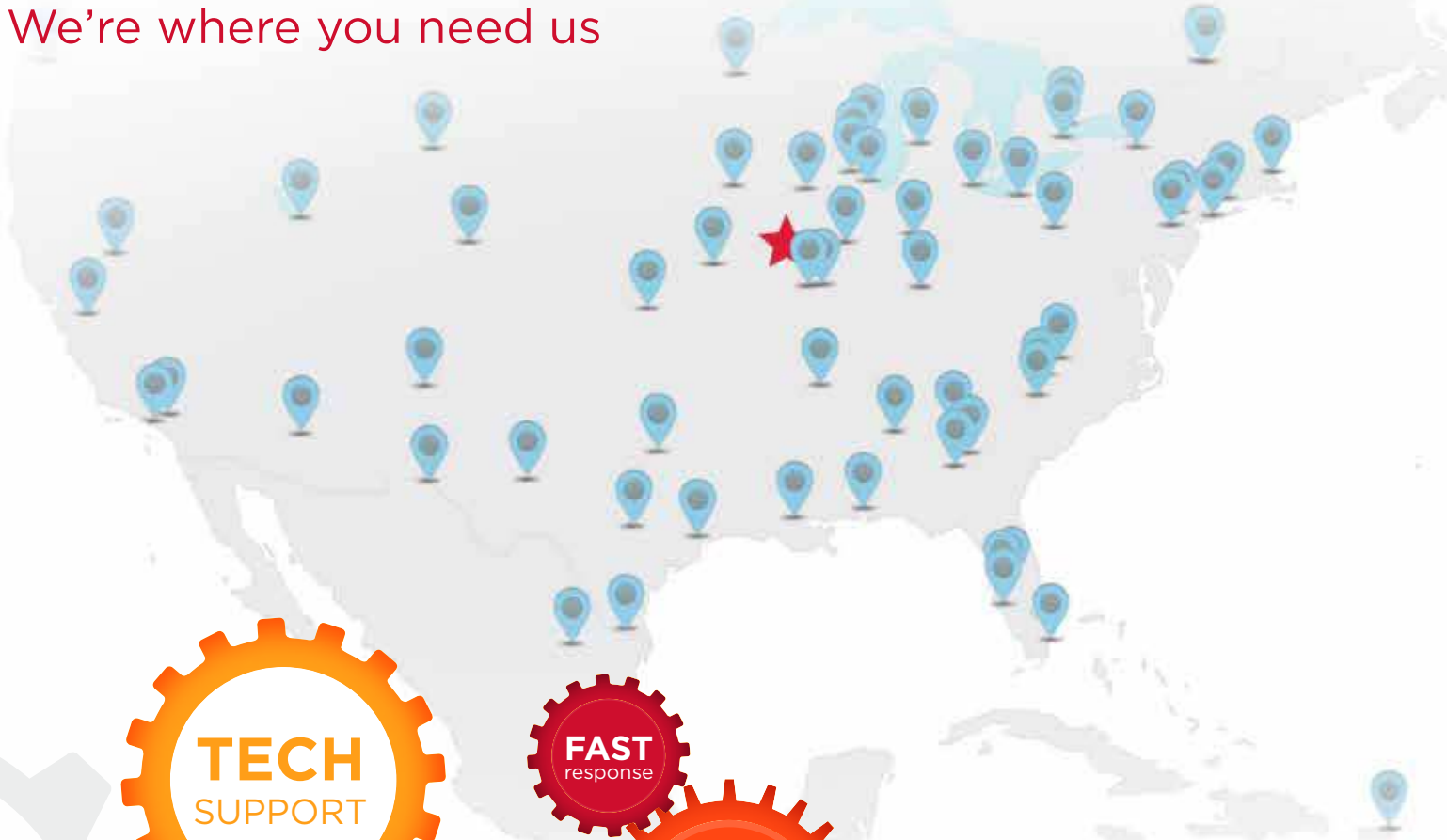

It's all about...

# the Sizing

QuickPik helps you customize  
our products to meet your demands

Try it now!  
Scan the QR code or visit:

[www.GDQuickPik.com](http://www.GDQuickPik.com)



## Sizing Made Simple

- Accessible information at your fingertips
- Compare & contrast blowers
- Fit technology to your exact needs
- Mobile-friendly design for your laptop, tablet & phone
- Will work off-line
- Set up and customize your profile
- Save selections for future reference

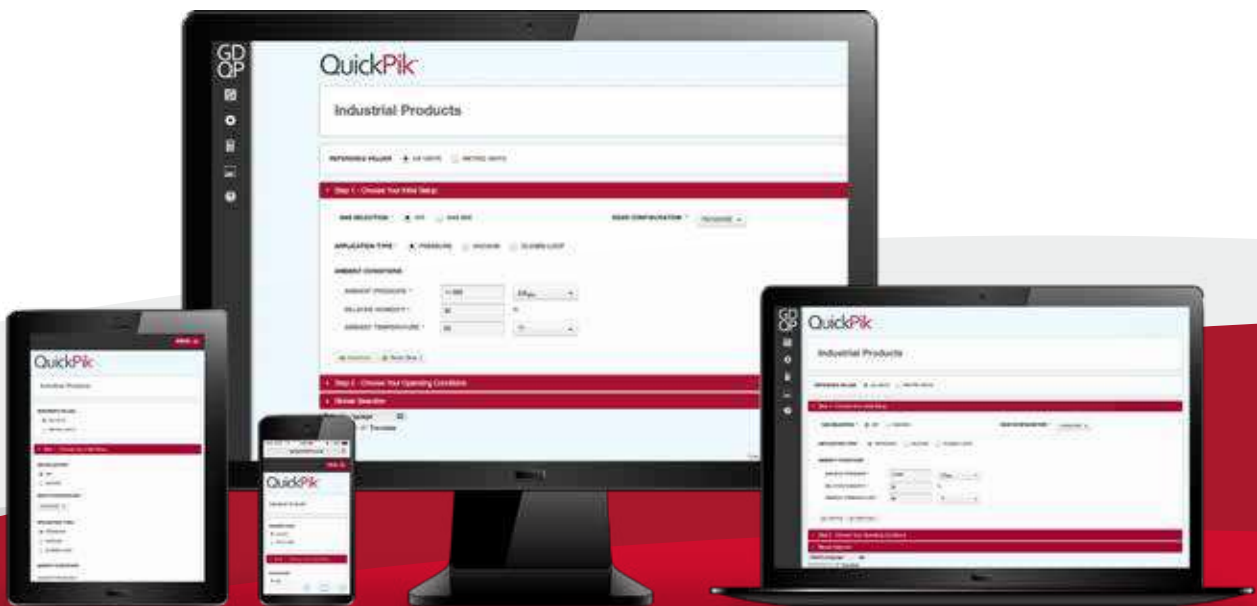

It's all about the...

# Variable Helix

The CycloBlower VHX utilizes a revolutionary  
**variable helix rotor design**

**Innovation is in our DNA.** Much like DNA, the rotor design of our blowers dictate what they become. Gardner Denver has a legacy of leadership developing the world's best blowers.

The CycloBlower VHX utilizes the **WORLD'S FIRST** variable helix screw rotor design. By adding a variable helix to our helical screw rotor design, we achieve new, unmatched levels of blower performance and efficiency.

## Why Variable Helix?

- Faster Internal Compression
- Significantly Larger Discharge Port
- Eliminates Air Losses
- Higher Efficiencies
- Higher Turndown Capability
- Save up to 35% on your Energy Costs



POWERED BY



To learn more about the CycloBlower VHX, visit [www.gardnerdenver.com/en/gdproducts/products/blowers/helical-screw-technology/cycloblower-vhx](http://www.gardnerdenver.com/en/gdproducts/products/blowers/helical-screw-technology/cycloblower-vhx) or scan the QR code.



CYCLOBLOWER® VHX

Technology	Specifications									
<b>3×5 VARIABLE HELIX SCREW</b>	<p><b>UP TO</b></p> <table border="0"> <tr> <td style="padding-right: 10px;"><b>775</b></td> <td>CFM</td> <td></td> </tr> <tr> <td><b>20</b></td> <td>PSI</td> <td></td> </tr> <tr> <td><b>18</b></td> <td>InHg</td> <td></td> </tr> </table>	<b>775</b>	CFM		<b>20</b>	PSI		<b>18</b>	InHg	
<b>775</b>	CFM									
<b>20</b>	PSI									
<b>18</b>	InHg									

HORSEPOWER SAVINGS

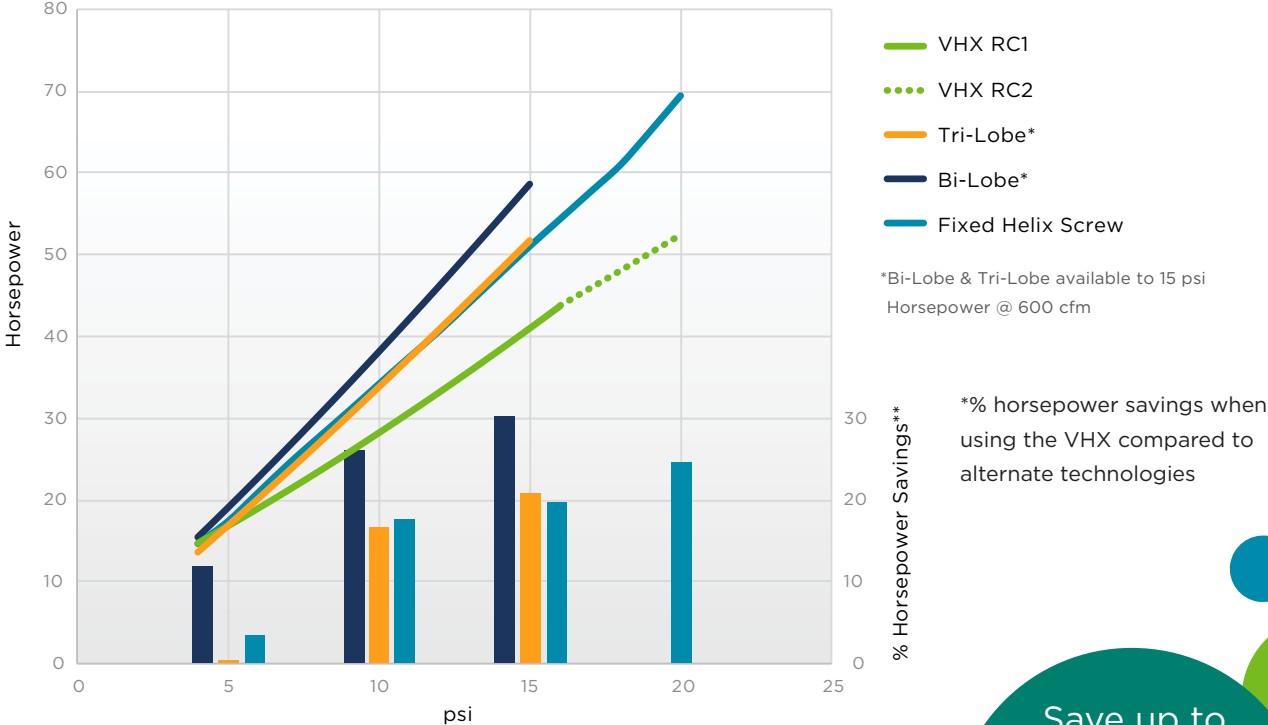

Save up to **35%** on Your Energy Costs

It's all about...

# Saving Money



## TOTAL COST OF BLOWER OWNERSHIP

- Energy
  - Maintenance
  - Investment
- Energy consumption is typically the largest cost of ownership
  - Save BIG with best-in-class energy efficiency
  - Lower your bottom line, increase your profits

## CYCLOBLOWER® H.E.

Technology	Specifications
3 × 5 HELICAL SCREW	<p style="color: red; font-weight: bold;">UP TO</p> <p style="font-weight: bold;">6,200</p> <p>CFM</p> <p style="font-weight: bold;">36</p> <p>PSI</p> <p style="font-weight: bold;">22</p> <p>InHg</p>

- Game-changing patented design
- Best-in-class energy efficiency
- Lower your bottom line, increase your profits
- Built with the best-of-the-best components
- Flexible options & installation





BRAKE HORSEPOWER REQUIREMENT COMPARISON  
at 2000 CFM

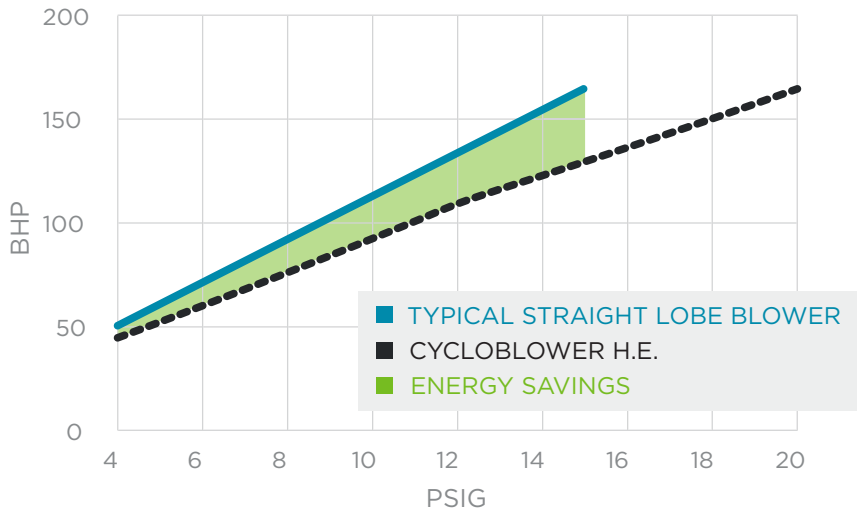

Innovation Working for You!

In many comparable applications, the CycloBlower operates more efficiently than other straight-lobe blowers. By requiring less brake horsepower (BHP) energy operating cost can be realized and greatly reduced.

INVEST WISELY  
REDUCE ENERGY

*Save Money*

CYCLOBLOWER H.E. VS. STRAIGHT LOBE

BLOWER TECHNOLOGY	BHP USED @ 15 PSI	ENERGY COST PER YEAR
Standard Straight Lobe	163	\$106,695
CycloBlower H.E.	129	\$84,604

\*Calculations based on the cost of providing 2,000 cfm of air for 8760 hours (1 year of 24/7 operation) assuming motor drive efficiency of 90% and electricity cost of \$0.09/kWh.

**\$22,090**

ANNUAL SAVINGS



It's all about...

# the Pulse

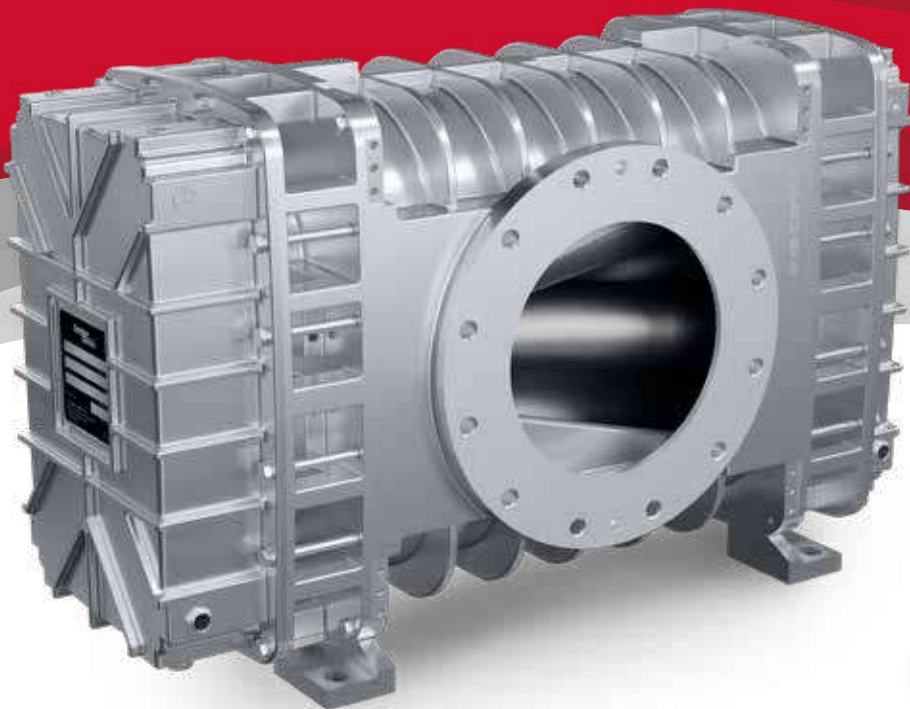

Protect your ears,  
Protect your **WORKFORCE**

## CHANGE IN PRESSURE PULSE

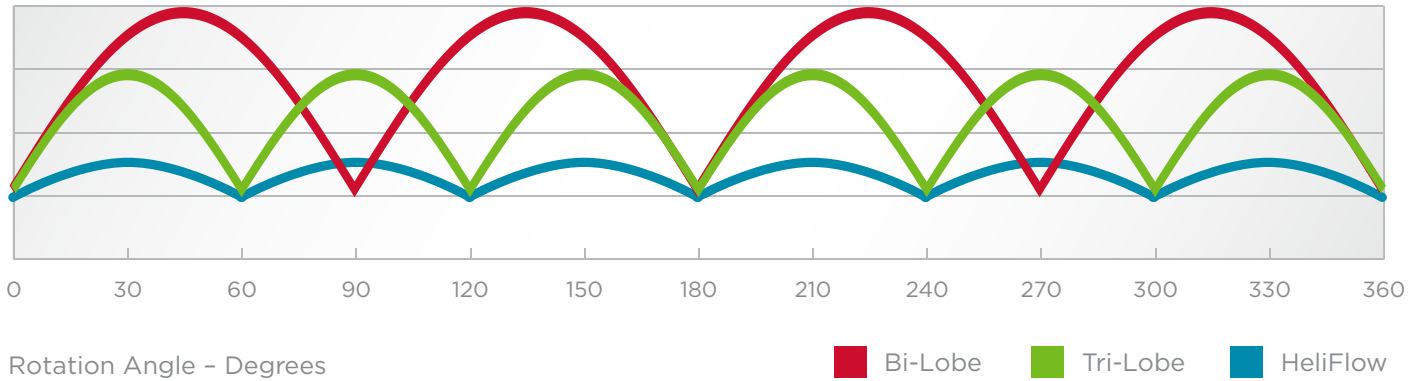

### Lower Noise

Discharge pulsation is the chief contributor to high noise levels. HeliFlow provides the lowest pressure pulse in the lobe blower market. This reduces noise levels by 4-7 dBA over similar sized, straight-lobe blowers.

### Reduced Pulsations

HeliFlow provides more consistent flow variation, reducing the potential for damage to downstream valves and instrumentation.

### Higher Reliability

Discharge pressure pulsation causes axial thrust and higher variations in torque resulting in reduced bearing life. The HeliFlow smooth pulse operation extends the life of the blower.

## HELIFLOW

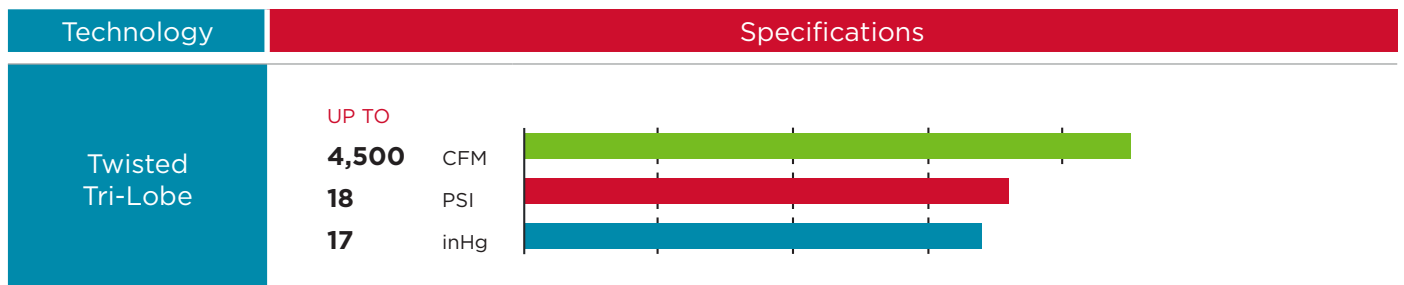

- Significant noise reduction over straight lobe technologies
- Lowest pressure pulses in lobe blower market
- Quiet, shock-free compression
- Reduced Pulsations = Quieter Operation
- Protect your employees hearing and improve safety
- Increased efficiencies

BACKED BY A  
**2 YEAR**  
WARRANTY

From date of initial use or  
30 months from date of shipment

It's all about...

# the RBS Series

Available in 29 Sizes

## Options

- Stainless Steel Options
- High Vacuum Options
- Force Feed Lubrication
- Pre-Package Availability
- Special Seal Options

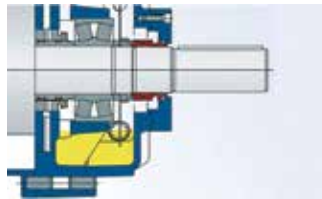

Single Mechanical Seal

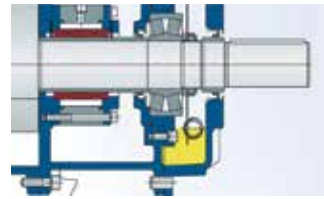

Double Mechanical Seal

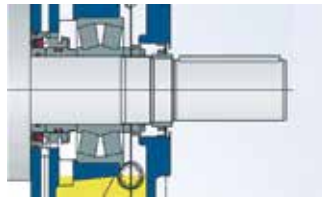

Lip Seal

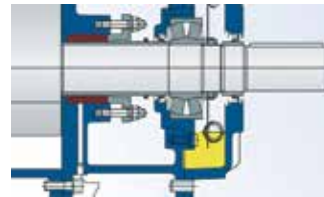

Gland Seal

## RBS SERIES

Technology	Specifications		
Tri-Lobe	UP TO <b>14,570</b> CFM	15 PSI	15 inHg

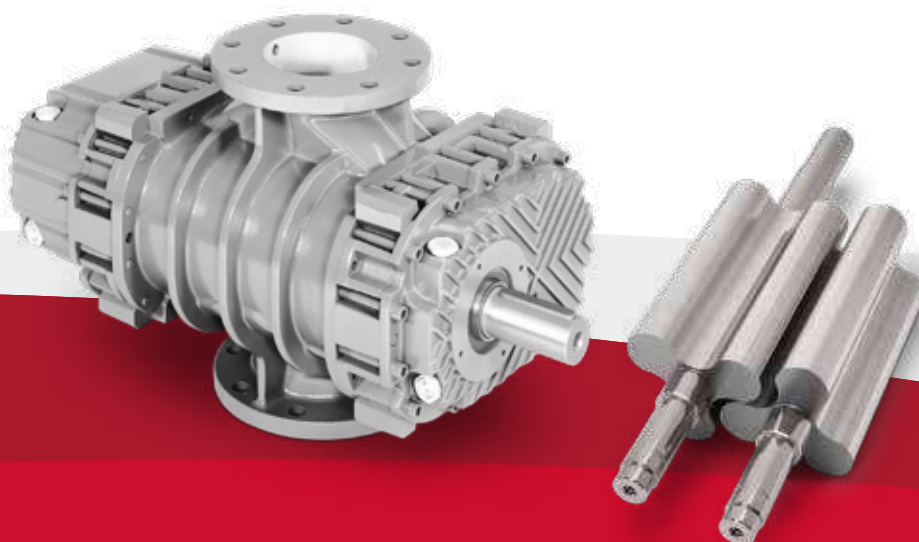

- Solid Tri-Lobe rotors offer quiet, efficient operation
- Robust design for reliability
- Flexible mounting options for easy drop in replacement
- Dual splash lubrication
- 100,000 hour bearing life
- Increased efficiencies

# Design Advantages

## Dual Splash Lubrication

Reliable dual splash lubrication on both the drive and gear ends for longer product life.

## Helical Gears

Helical timing gears for smooth and quiet operation at all speeds.

## Leak Free Operation

Piston rings and flinger maximize seal life in continuous severe duty applications.

## Durable Shafts

High strength shafts that allow higher operating pressures and rotation speeds.

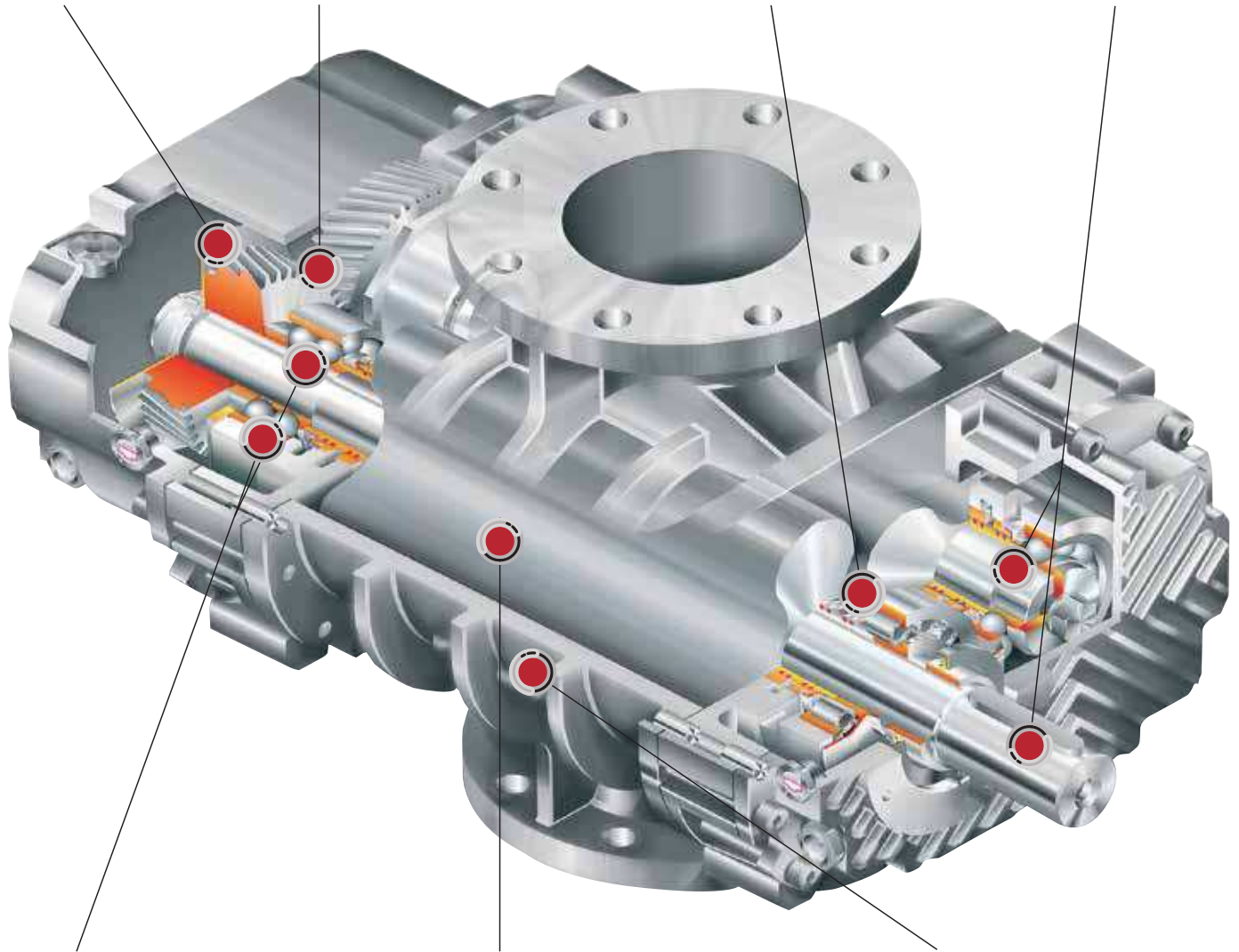

## Long Life Bearings

Reinforced roller bearings are calculated for a lifespan of 100,000 hours under the most severe operating conditions.

## Three-Lobe Rotors

Involute Three-Lobe Rotors offer the highest performances and efficiencies.

## Single Piece Cylinder

High strength impeller case is heavily ribbed and machined from a single piece of cast iron to retain internal clearances and improve heat dissipation.



It's all about...

# Toughness

## Designed for Dusty, Abrasive Environments

- Single piece, high-strength rotor casting
- Oversized bearings
- Dual-splash lubrication
- Advanced oil and air seals
- ISO 9001 quality certified

Built for YOU, built to LAST



## DUROFLOW

Technology	Specifications		
Bi-Lobe	UP TO <b>4,300</b>	CFM	
	<b>15</b>	PSI	
	<b>16</b>	inHg	

- Designed for dusty, abrasive environments
- Solid rotor design prevents build up
- Dual splash lubrication for longer product life
- Leak free operation



It's all about...

# Cool Air



Sutorbilt 8000 Series



Sutorbilt 4500 Series



Our blowers are designed to **run cooler & protect** your product



Sutorbilt Legend Series

### Hot Air Spoils Product

#### Sutorbilt

- Coolest in its class
- Dual-splash lubrication, air gap, separate sump, cylinder
- The most versatile blower available
- Over 240 configuration options
- Grease or dual splash lubrication
- Quiet series option

For over 75 years, the Sutorbilt family of positive displacement blowers and vacuum pumps have been synonymous with quality and reliability. The Sutorbilt line is at the heart of an ever-expanding variety of air solutions working every minute of every day around the globe.



### SUTORBILT

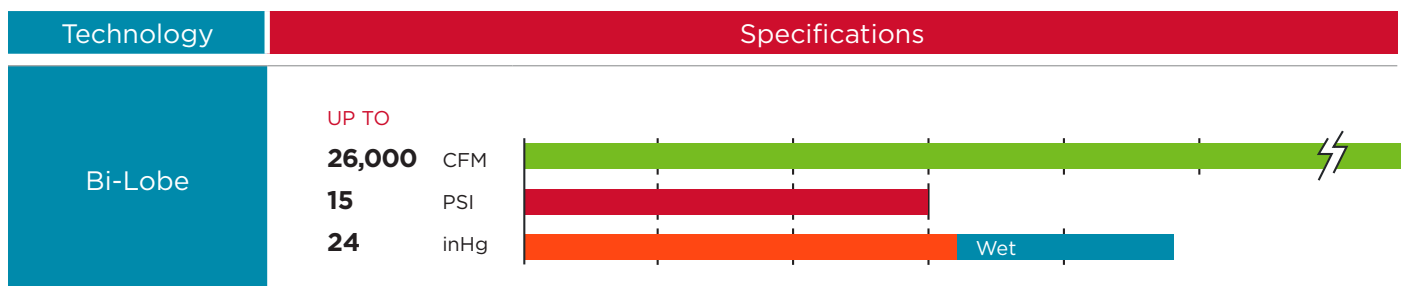

It's all about...

# the Complete Package

Gardner Denver has more blower package options than anyone else

We can help you customize your system to meet your needs. More technology designs provides tailored options for you.

- Smart Design
- Easy Maintenance
- Compact Installation
- Quiet Operation
- Enclosed or Unenclosed Available
- Inverter Duty Motors for VFD Capabilities

## IQ-RB

### SIMPLE

Straight Tri-Lobe

Pressure to 15 PSI

Vacuum to 15 inHg

5,500 Max CFM

3-500 HP

Fixed Speed

Mechanical Gauges



## IQ

### SMART

Twisted Tri-Lobe  
Pressure to 15 PSI  
Vacuum to 17 inHg  
1,500 max CFM  
7.5-100 HP  
Fixed Speed or VFD  
AirSmart Controller



## IQ-HE

### EFFICIENT

3x5 Helical Screw  
Pressure to 36 PSI  
5,625 Max CFM  
7.5-500 HP  
Fixed Speed  
AirSmart G2 Controller



Patented  
Rotor Profile  
High Efficiency  
up to 36 PSI



The leader in every market we serve  
by continuously improving all business processes  
with a focus on innovation and velocity

**Gardner  
Denver**<sup>®</sup>

**Gardner Denver, Inc.**

1800 Gardner Expressway  
Quincy, IL 62305  
866-428-4890

[www.gardnerdenver.com/gdproducts](http://www.gardnerdenver.com/gdproducts)



©2018 Gardner Denver, Inc. Printed in U.S.A.  
PD-APP-MILL 3rd Ed. 3/18

 Please recycle after use.