



# PRICE PUMP CO.

Air Operated Diaphragm Pumps

# AOD<sup>®</sup>



# PRICE<sup>®</sup>AOD<sup>®</sup>...maximum performance... minimum maintenance...year-in and year-out.

When you invest in pumping equipment manufactured by Price<sup>®</sup> Pump Company, you buy more than just a pump—there is the assurance of knowing that in addition to receiving highly dependable, top quality pumps, you receive the engineering excellence, application expertise and factory support necessary to make your pumping applications trouble-free.

Our AOD<sup>®</sup> line is available in 7 sizes from 1/4" (6.35mm) through 3" (76.2mm) in aluminum, cast iron, stainless steel, polypropylene and PVDF. Elastomers include Neoprene, Buna-N, Viton<sup>®</sup>, Teflon<sup>®</sup>, Santoprene<sup>®</sup>, and Nordel<sup>®</sup>. AOD<sup>®</sup> pumps provide clean, safe, reliable, low maintenance performance in literally hundreds of applications.\*

## AOD<sup>®</sup>...a pump with a difference.

AOD pumps operate substantially different from conventional electrically driven centrifugal or positive displacement pumps. These differences can make the AOD the most cost effective solution to your most difficult pumping problems.

## AOD<sup>®</sup> differences add up to advantages for you!

Just look at what the AOD<sup>®</sup> can do:

- Handles the widest variety of fluids of any single type of pump. High viscosity liquids that can't be handled by centrifugal pumps, low viscosity liquids that can't be handled by other positive displacement pumps—even low density powder can be handled effectively.
- Has an infinitely variable flow rate from 0 to 230 GPM (52 m<sup>3</sup>/hr), with maximum air inlet pressures up to 125 PSI (8.8 kg/cm<sup>2</sup>). Perfect for batching applications.
- Self-priming—the AOD<sup>®</sup> can be mounted above or below liquid level—even submerged.
- It can operate against a closed discharge without pump damage. This makes AOD<sup>®</sup> an excellent choice for bulk dispensing, batching or feeding a pressurized system.
- Runs dry without damage to the pump or piping system, making the AOD<sup>®</sup> suited for transfer applications, emptying tanks and dewatering.
- Uses compressed air—inherently explosion-proof. No dynamic electrical components to spark. No heat generating components to cause product flashing.
- Handles shear sensitive or fragile liquids like paint, ink and clay slips.
- Does not require complex controls or expensive auxiliary equipment to install and operate.

## The AOD<sup>®</sup>...a great utility pump used throughout industry.

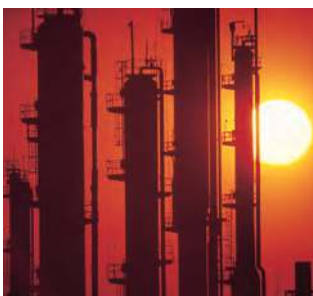

## Stall-free performance.

Our state-of-the-art “posi-shift” air valve design insures reliable stall-free operation in all types of low pressure and troublesome start/stop applications. Regardless of the application or the conditions of service, **AOD®** users can operate with confidence, knowing that their **AOD®** will start reliably.

- Widest performance envelope—operates on as low as 5 PSI (.35 kg/cm<sup>2</sup>) and as slow as 1 GPH (3.5 liter/hr).
- Bulk transfer applications—even dry powder can be handled efficiently.
- Confidence in start/stop batching applications.
- Confidence for “on-demand” dispensing systems.
- Viscous liquids, paint and inks are effectively handled.
- OEMs safeguard their reputation with AOD®. We’ll be here to insure the after sales service we promise.
- Excellent on low flow chemical injection systems.



## Oil-less operation.

No metal to metal wearing surfaces. State-of-the-art materials and precision-manufacturing techniques combine to provide the industry’s original completely oil-less design. This design means:

- **no oil misting into the environment** ■ **no unhealthy working conditions** ■ **no oil, lubricants or grease to contaminate your products.** Our oil-less design results in lower operating and maintenance costs. This design has been field proven, working trouble-free since its introduction over 20 years ago.

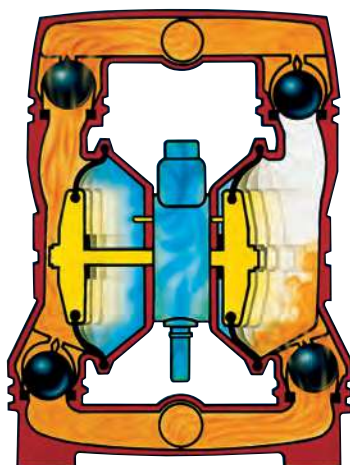

### What do oil pots actually cost?

Typical lubrication costs for conventional air-operated double diaphragm pumps.

Scheduled Maintenance	Man hours	Hourly Labor Cost	Annual Oil Cost	Annual Lubrication Cost
Twice/week	1/4	\$75	\$96 (48 qts)	\$2046.00

*These annual savings are directly attributable to the oil-less air valve. Because the AOD® pump does not use oil, should a diaphragm failure occur, product would not be contaminated—a cost which must be added to the costs of pumps that require lubrication.*

# Engineering excellence...fewer parts...fewer problems.

Our engineers have achieved stall-free, oil-less operation while using the **fewest air valve** components of any major diaphragm pump manufacturer. Our pilot spool provides a continuous high pressure signal to the main power spool, assuring a positive shift under all operating conditions. The patented design is so effective, yet so simple, it truly defines the term “engineering excellence”.

- Main power spool controls air inlet/exhaust porting and is externally accessible for easy inspection.
- No “O” rings to cut or roll out of position. No “elephant stands”. No metal-to-metal wearing parts.
- Balanced main spool minimizes wear on spool and housing—no need to replace as an expensive set.

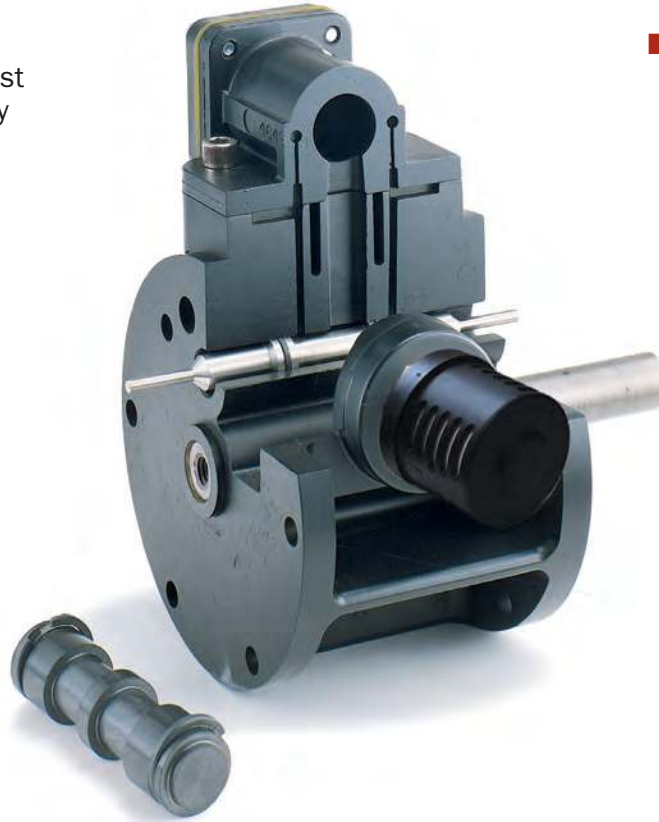

- Stall-free performance... pilot spool precisely controls positioning of the main power spool to eliminate stalling and increase efficiency.
- Nitrided shaft provides longer life than steel shafts.
- Specially modified fluorocarbon resin materials glide smoothly without lubrication.
- Muffler provides “whisper quiet” performance
- 5 year warranty on both main spool and pilot spool.\*

## Minimize your maintenance with our AOD®.

The externally servicable main spool makes inspection quick and easy.

*Fewer parts are used in our air valve to assure top performance with low maintenance.*



Phenolic main spool and stainless steel pilot spool!



Long-lasting AOD® diaphragms extend service life.

## Spool removal is simple as this:



\* See Price Pump Terms and Conditions for Details. (Does not apply to “Y” Series Pumps)

# Specifications

## Technical Information—Metallic AOD® Pumps

Price Pump Co. AOD® pumps have distinct design advantages that make them very versatile and cost effective. Technical information and specifications are shown in the tables and on the typical, dimensional outline drawing. The performance shown reflects an average performance for all metallurgies and all elastomers including Teflon®.

Model	MAX FLOW GPM (LPM)	Displacement Gal (Liters)		Max Inlet PSI (BAR)	Max Solid Size Inches (mm)	High Temp Limit °F (°C)			Low Temp Limit °F (°C)			Shipping Weight LBS (kg)		
		ELAS	TEF			AL	SS	CI	AL	SS	CI	AL	SS	CI
<b>1.5 AOD</b> (Bolted)	75 284	.35 1.3	.20 .75	125 8.8	3/16 4.7	248 120	248 120	248 120	32 0	32 0	32 0	48 21.8	85 36.6	88 39.9
<b>2 AOD</b> (Bolted)	170 643	.85 3.2	.80 3.0	125 8.8	3/8 9.5	248 120	248 120	248 120	32 0	32 0	32 0	96 43.5	165 74.8	161 73
<b>3 AOD</b> (Bolted)	230 871	.87 3.3	.82 3.1	125 8.8	7/16 11	248 120	248 120	248 120	32 0	32 0	32 0	124 56.2	230 104	223 101

### Dimensions for AOD® Metallic Pumps

Model	Material	Ports NPT/BSP		Air Inlet Size	Air Outlet Size	Dimensions Inches (mm)							
		Suction	Discharge			A	B	C	D	E	F	G	H
<b>1.5 AOD</b> (Bolted)	AL	1 1/2"	1 1/2"	3/8" FNPT	1/2" FNPT	20.63 524	11 279	19.9 429	1.63 41	10.38 264	19.38 492	6.75 171	13.19 335
	SS	1 1/2"	1 1/2"	3/8" FNPT	1/2" FNPT	20.63 524	11 279	19.9 429	1.63 41	10.38 264	19.38 492	6.75 171	13.19 335
<b>2 AOD</b> (Bolted)	AL	2"	2"	3/4" FNPT	3/4" FNPT	26.75 679	14.75 375	20.44 519	2 51	19.13 486	25.19 640	9.25 235	14.19 360
	SS	2"	2"	3/4" FNPT	3/4" FNPT	26.75 679	14.75 375	20.44 519	2 51	19.13 486	25.19 640	9.25 235	14.19 360
<b>3 AOD</b> (Bolted)	AL	3"	3"	3/4" FNPT	3/4" FNPT	29.50 749	14.75 375	20.13 511	2.50 64	20.31 516	27.38 695	9.25 235	14.88 378
	SS	3"	3"	3/4" FNPT	3/4" FNPT	29.50 749	14.75 375	20.13 511	2.50 64	20.31 516	27.38 695	9.25 235	14.88 378

**Bolted**

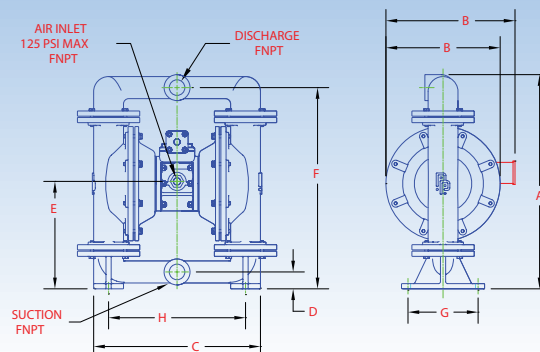

# Technical Information—Metallic AOD® Pumps

Price Pump Co. AOD® pumps have distinct design advantages that make them very versatile and cost effective. Technical information and specifications are shown in the tables and on the typical, dimensional outline drawing. The performance shown reflects an average performance for all metallurgies and all elastomers including Teflon®.

Model/ Specification	MAX FLOW GPM (LPM)	Displacement Gal (Liters)		Max Inlet PSI (BAR)	Max Solid Size Inches (mm)	High Temp Limit °F (°C)			Low Temp Limit °F (°C)			Shipping Weight LBS (kg)		
		ELAS	TEF			AL	SS	CI	AL	SS	CI	AL	SS	CI
<b>.25 AOD-Y</b>	3.4	.009	.0085	100	.004	212	212	----	----	----	----	4.3	6.9	----
	12.9		.032			6.9	100	100	----	----	----	1.95	3.13	----
<b>.5 AOD-Y</b>	12.4	.03	.031	100	1/32	248	248	----	----	----	----	12	16.6	----
	46.9		.117			6.9	1.0	120	120	----	----	5.44	7.53	----
<b>.75 AOD-Y</b>	27.3	.14	.10	100	1/16	248	248	----	----	----	----	24.8	35.8	----
	103		.38			6.9	1.6	120	120	----	----	11.25	16.23	----
<b>1 AOD</b>	35	.18	.12	125	1/8	248	248	248	32	32	32	34	45	53
	132		.45			8.8	3.2	120	120	120	0	0	0	15.4
<b>1.5 AOD</b>	75	.35	.20	125	3/16	248	248	248	32	32	32	48	85	88
	284		.75			8.8	4.7	120	120	120	0	0	0	21.8
<b>2 AOD</b>	170	.85	.80	125	3/8	248	248	248	32	32	32	96	165	161
	643		3.0			8.8	9.5	120	120	120	0	0	0	43.5
<b>3 AOD</b>	230	.87	.82	125	7/16	248	248	248	32	32	32	124	230	223
	871		3.1			8.8	11	120	120	120	0	0	0	56.2

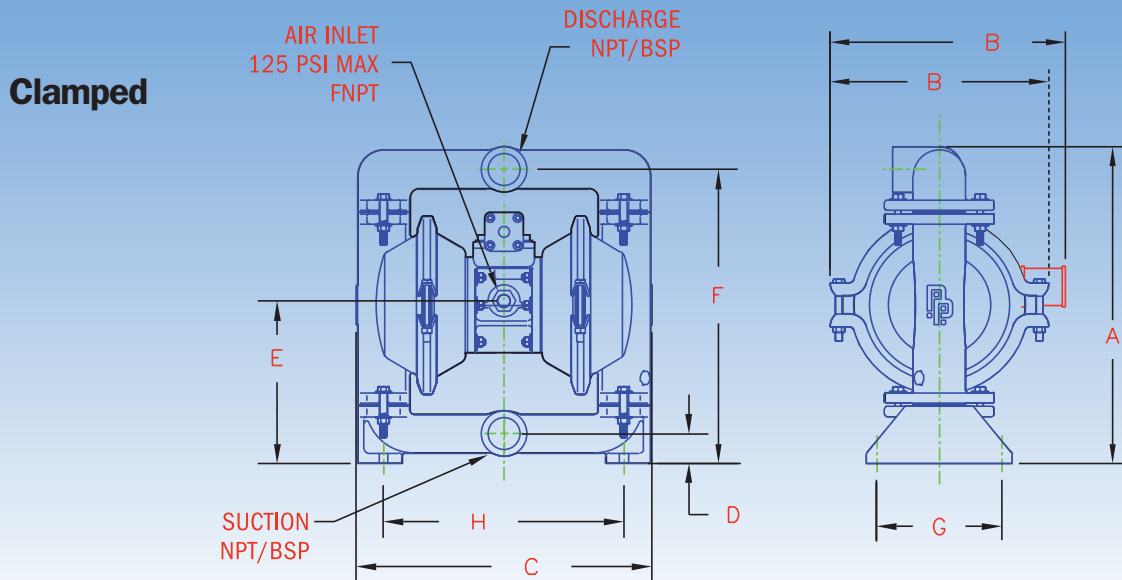

Suction and Discharge manifold positions will vary per model.

## Dimensions for AOD® Metallic Pumps

Model	Material	Ports NPT/BSP		Air Inlet Size	Air Outlet Size	Dimensions Inches (mm)							
		Suction	Discharge			A	B	C	D	E	F	G	H
<b>.25 AOD-Y</b>	AL	1/4"	1/4"	1/4" FNPT	3/8" FNPT	5.87 149	4.50 115	4.50 115	.984 25	3.50 89	3.66 93	3.23 82	4.13 105
	SS	1/4"	1/4"	1/4" FNPT	3/8" FNPT	5.87 149	4.50 115	4.50 115	.984 25	3.50 89	3.66 93	3.23 82	4.13 105
<b>.5 AOD-Y</b>	AL	1/2"	1/2"	1/4" FNPT	3/8" FNPT	10.71 272	6.22 158	8.66 220	1.77 45	6.73 171	9.45 240	4.13 105	4.80 122
	SS	1/2"	1/2"	1/4" FNPT	3/8" FNPT	9.70 248	6.22 158	8.31 211	1.42 36	6.26 159	8.86 225	4.13 105	4.80 122
<b>.75 AOD-Y</b>	AL	3/4"	3/4"	3/8" FNPT	3/4" FNPT	12.60 320	10.93 278	9.80 249	1.77 45	6.57 167	11.3 288	5.51 140	7.68 195
	SS	3/4"	3/4"	3/8" FNPT	3/4" FNPT	12.60 320	10.93 278	9.80 249	1.77 45	6.57 167	11.3 288	5.51 140	7.68 195
<b>1 AOD</b>	AL	1"	1"	3/8" FNPT	1/2" FNPT	14.50 365	7.50 191	11.625 284	1.313 33	7.375 187	13.313 338	5.50 133	9.50 241
	SS	1"	1"	3/8" FNPT	1/2" FNPT	14.50 365	7.50 191	11.625 284	1.313 33	7.375 187	13.313 338	5.50 133	9.50 241
	CI	1"	1"	3/8" FNPT	1/2" FNPT	14.50 365	7.50 191	11.625 284	1.313 33	7.375 187	13.313 338	5.50 133	9.50 241
<b>1.5 AOD</b>	AL	1-1/2"	1-1/2"	3/8" NPT	1/2" NPT	17.06 433	12.0 305	16.875 429	2.0 51	8.313 211	15.75 400	5.875 149	13.188 335
	SS	1-1/2"	1-1/2"	3/8" NPT	1/2" NPT	17.06 433	12.0 305	16.875 429	2.0 51	8.313 211	15.75 400	5.875 149	13.188 335
	CI	1-1/2"	1-1/2"	3/8" NPT	1/2" NPT	17.375 441	12.0 305	16.313 414	1.625 41	8.875 225	16.125 410	6.875 175	13.188 335
<b>2 AOD</b>	AL	2"	2"	3/4" NPT	3/4" NPT	24.313 618	14.375 365	18.75 476	2.188 56	17.44 433	22.69 576	9.25 235	14.25 362
	SS	2"	2"	3/4" NPT	3/4" NPT	24.313 618	14.375 365	18.75 476	2.188 56	17.44 433	22.69 576	9.25 235	14.25 362
	CI	2"	2"	3/4" NPT	3/4" NPT	24.625 618	14.375 365	17.875 454	2.0 51	18.0 457	22.938 583	8.813 224	14.188 360
<b>3 AOD</b>	AL	3"	3"	3/4" NPT	3/4" NPT	30.438 773	14.375 365	21.438 545	3.125 79	21.0 533	28.313 719	12.0 305	15.563 395
	CI	3"	3"	3/4" NPT	3/4" NPT	28.325 721	14.325 365	19.875 505	2.50 64	19.69 500	26.125 664	10.313 270	14.875 378

# Non-metallic, oil-less, stall-free, non-icing design means top performance—year after year.

■ Polypropylene or PVDF wetted parts offer optimum chemical resistance and cost effective handling of aggressive chemicals.

■ The simply designed stall-free, oil-less air valve provides long trouble-free service.

■ The low profile, stable design is easily installed in close quarters.



■ Dual exhaust with expanding diffusion passages reduce icing during operation.

■ No O-rings! All dynamic sealing is completed without the use of O-rings resulting in less wear, less downtime, and absolutely no lubrication.

■ Sturdy design operates safely on plant air up to 125 psi (8.5 Bar).



■ Dual air connections accommodates air from either side of the air valve for installation versatility and convenience.

■ Dual mufflers provide “whisper-quiet” performance.

■ Fully engaged, plastic mated surfaces prevent stress failure due to over torquing of bolts.

■ Single piece, end ported suction and discharge manifolds eliminate potential leak paths.



All bolted design for positive sealing utilizes corrosion resistant hardware for extended, leak-proof service. 18-8 Stainless fastener option available, contact factory.





Unique 316 stainless steel spool housing design retains all of the patented stall-free, oil-less features while improving its functional reliability and corrosion resistance.

For routine cleaning, the main spool is externally serviceable, saving time and maintenance expense.



AOD® offers both ANSI (left) and DIN compatible (right) suction and discharge flanges to meet all global requirements.

Integrally molded feet and suction manifold create a sturdy, non-corrosive support base.



Solid, glass-filled polypropylene air chambers and air valve body for maximum chemical resistance in highly corrosive environments.

Air chambers are integrally molded into the air valve body enhancing safety by eliminating a potential leak path.

Dual exhaust paths with increasing diffusion passages (patent applied for) provide non-icing operation.



Self locking outer clamp plates prevent the possibility of accidental decoupling during operation.



Teflon® ball valves, seats and diaphragms are chemically inert and are easily replaced. Plastic ball valve cages are simple to remove and inexpensive to replace.



Stainless steel inserts (300 series) simplify assembly and reduce the amount of hardware.

Low profile liquid chamber inlet prevents build-up of sediment and solids. This self cleaning design extends diaphragm life and lowers maintenance costs.

# Technical Information—Non-Metallic AOD® Pumps

Price Pump Co. AOD® pumps have distinct design advantages that make them very versatile and cost effective. Technical information and specifications are shown in the tables and on the typical, dimensional outline drawing. The performance shown reflects an average performance for all materials and all elastomers including Teflon®.

Model/ Specification	MAX FLOW GPM (LPM)	Displacement		Max Inlet PSI (BAR)	Max Solid Size Inches (mm)	High Temp Limit °F (°C)		Low Temp Limit °F (°C)		Shipping Weight Lbs (kg)	
		ELAS	TEF			PolyPro	PVDF	PolyPro	PVDF	PolyPro	PVDF
<b>.25 AOD-Y</b>	3.4 12.9	.009	.0085 .035	100 6.9	.004 .1	180 82	212 100	32 0	32 0	4.0 1.8	4.7 2.1
<b>.5 AOD</b>	15 57	.04 .014	.014 .05	125 8.8	1/8 3.2	180 82	248 180	32 0	32 0	11 5.0	13.5 6.1
<b>.75 AOD-Y</b>	27.3 103	.14 .53	.10 .38	100 6.9	1/16 1.6	180 82	N/A	32 0	N/A	22.6 10.25	N/A
<b>1 AOD</b>	35 132	.12 .45	.10 .38	125 8.8	3/16 4.7	180 82	248 120	32 0	32 0	39 17.7	44.5 20.2
<b>1.5 AOD-Y</b>	115 435	.74 2.8	.37 1.4	100 6.9	9/32 7.0	180 82	248 120	32 0	32 0	78 35.4	78 35.4
<b>2 AOD</b>	170 643	.85 3.2	.80 3.0	125 8.8	3/8 9.5	180 82	248 120	32 0	32 0	82 37	105 47
<b>3 AOD-Y</b>	213 806	2.25 8.5	1.0 3.8	100 6.9	13/32 10.0	180 82	N/A	32 0	N/A	178 81	N/A

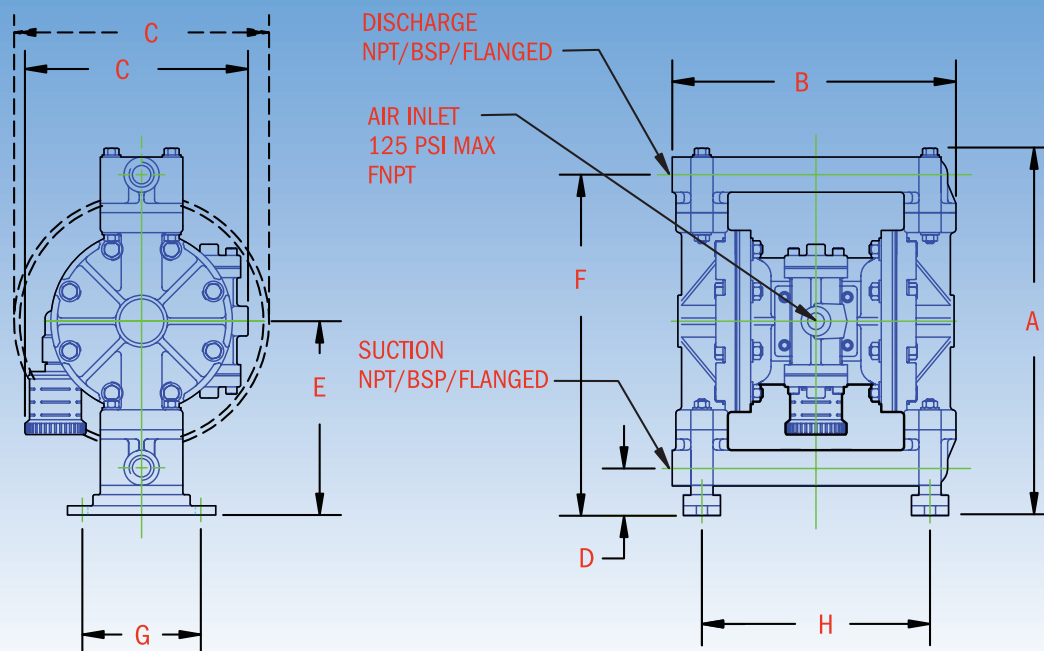

## Dimensions for AOD® Non- Metallic Pumps

Model	Material	Ports NPT/BSP ANSI / DIN		Air Inlet Size	Air Outlet Size	Dimensions Inches (mm)							
		Suction	Discharge			A	B	C	D	E	F	G	H
<b>.25 AOD-Y</b>	P	1/4"	1/4"	1/4" FNPT	3/8" FNPT	5.79 147	6.14 156	4.50 115	.984 25	3.46 88	3.54 93	3.23 82	3.86 98
	K	1/4"	1/4"	1/4" FNPT	3/8" FNPT	5.79 147	6.1 156	4.50 115	.984 25	3.46 88	3.54 93	3.23 82	3.86 98
<b>.5 AOD</b>	P	1/2"	1/2"	3/8" FNPT	3/8" FNPT	12.375 314	9.563 243	7.50 191	1.625 41	6.563 167	11.50 292	4.00 102	7.69 195
	K	1/2"	1/2"	3/8" FNPT	3/8" FNPT	12.063 306	9.375 238	7.50 191	1.625 41	6.26 159	11.938 287	4.00 102	7.69 195
<b>.75 AOD-Y</b>	P	3/4"	3/4"	3/8" FNPT	3/4" FNPT	14.49 368	12.44 316	10.93 278	2.60 66	7.68 195	12.8 324	4.92 125	7.99 203
<b>1 AOD</b>	P	1"	1"	3/8" FNPT	1/2" FNPT	21.50 546	8.75 222	16.563 421	3.375 86	11.56 294	19.375 492	3.625 92	9.563 243
	K	1"	1"	3/8" NPT	1/2" NPT	21.125 537	8.063 205	16.50 419	3.438 87	11.50 292	19.0 483	3.50 89	9.50 241
<b>1.5 AOD-Y</b>	P	1-1/2"	1-1/2"	3/4" NPT	1" NPT	22.44 570	15.75 400	12.20 310	4.4 112	23.46 596	26.90 682	10.83 275	7.87 200
<b>2 AOD</b>	P	2"	2"	3/4" NPT	3/4" NPT	25.063 637	14.75 375	23.875 606	3.50 89	19.063 484	22.063 560	9.00 229	13.50 343
	K	2"	2"	3/4" NPT	3/4" NPT	25.063 637	14.75 375	23.875 606	3.50 89	19.063 484	22.063 560	9.00 229	13.50 343
<b>3 AOD-Y</b>	P	3"	3"	3/4" NPT	1" NPT	41.10 1044	22.83 580	19.02 483	5.08 129	29.8 758	37.40 949	17.64 448	15.24 387

## A wide range of AOD® accessories and assistance.

We can supplement your AOD® applications with a range of accessories and pump configurations along with the technical expertise required for trouble-free pumping. Inquire about customized pump packages designed and manufactured to meet the needs of your specific application.

### Pulsation Dampeners

Our pulsation dampeners and surge suppressors can economically eliminate up to 98% of low frequency, high amplitude pulsations produced by diaphragm pumps. The right sizes and materials of construction are available for every application.



- Provide smooth and continuous, almost linear flow—prevents splashing of liquids or chemicals.
- Prevent pipe and joint fatigue—protect the environment from contamination by chemical leaks.
- Absorb shock from quick closing valves—protecting against catastrophic pipe failure.
- Insure accuracy and protection of in-line meters and instruments.
- Provide suction stabilization at pump inlet—easing the pump's

### Filter Regulator

Filters plant air to 5 microns while allowing precise control of AOD®



### YSC-2EX Cycle Timer

The YSC-2EX Controller provides a reliable cost effective solution for accurate speed and flow control. No extensive programming required.



### Diaphragm Monitoring

The DM-2 Diaphragm Monitoring System is designed to protect your Price pump against damage from corrosive, aggressive, or other harmful pumped fluids. Powered by standard line current, the DM-2 automatically disrupts air supply pressure to the pump and/or activates an indicator the moment a diaphragm leak is detected.



### Two Pumps In One

Split manifold options add to the flexibility of Polypro AOD®; dual suction for 1-1 blending, dual discharge for halving pumpage or "quad port" arrangement to use one pump in place of two.



Price® Pump Co. manufacturing facility in Sonoma, CA.

**At Price® Pump, we back our products with the kind of prompt and efficient service you expect from a leading pump supplier. Our expert technical personnel provide timely and accurate information on the performance and availability of every Price® pump. We can help you select the right pump for a unique application, and often suggest alternatives which improve pump performance and save you money. Pump modifications and expedited deliveries are our specialty.**

**Price® Pump Company supplies AOD® pumps for O.E.M., agricultural, chemical, pollution control, waste and water treatment, and many other industrial applications. Our pumps are suitable for liquids ranging from water, oils, solvents and chemicals to strong acid or alkaline solutions. Our AOD® pumps also handle a wide range of viscous fluids.**

**Every Price® pump is built to deliver extended, trouble-free performance under the most punishing industrial conditions. We use only the highest quality parts and materials. Our pumps are manufactured with sophisticated production equipment and subjected to exacting quality control procedures. We invite you to compare our prices and our quality the next time you need a reliable AOD® pump.**

**See our Pump Selection Program at [pricepump.com](http://pricepump.com)**



\*AOD® is a registered trademark of Price®Pump Co.; Viton® and Nordel® are registered trademarks of Dupont Dow Elastomers; Teflon® is a registered trademark of Dupont; Santoprene® is a registered trademark of Monsanto Company.

**PRICE PUMP CO.**

21775 Eighth St. East  
Sonoma, CA 95476-0329  
(800) 345-PUMP  
(707) 938-8441 FAX: (707) 938-0764  
[www.pricepump.com](http://www.pricepump.com)  
e-mail: [sales@pricepump.com](mailto:sales@pricepump.com)

Rev. 2012

