

Self-Priming Magnetic Drive Pump



SMX Series of magnetically driven non-metallic pumps offer an innovative true self-priming design with no mechanical seals for years of trouble-free service. SMX features our self-radiating bearing structure and our proven non-contact dry-run capability enabling them to withstand the rigors of abnormal operating conditions. Utilizing an integral priming and air separation chamber, the SMX Series offer superior repeatable self-priming performance.

- **Quick priming** - Able to dry lift up to 13 feet in under 90 seconds.
- **Motor options** - SMX(F) series mounts to NEMA C-faced motors allowing for limitless voltage and service choices.
- **Expanded versatility** - The SMX has a modular structure to handle liquids with high specific gravities. Use of standard motors extends the range of applications.
- **Easy maintenance** - The pump wet end can be removed from the motor as a complete assembly without dismantling, thanks to an additional rear casing support. The simple, rugged design with a minimum number of parts allows for easy maintenance.
- **Enhanced durability under abnormal operation** - Our original self-radiation structure (Patented) efficiently disperses bearing friction heat to protect the pump under abnormal operating conditions. In addition, our non-contact structure prevents contact between rear thrust face and bearing, to eliminate heat buildup during dry running.



SMX

series

Model Code

SMX-F 22 0 CF V X U

Series symbol

SMX: GFRPP type
SMX-F: CFRETFE type

Pump size

22 : 1" x 1" Flanged
44 : 1.5" x 1.5" Flanged
54 : 2" x 1.5" Flanged

Motor output

0 : 0.5 HP
1 : 1.0 HP
2 : 2.0 HP
3 : 3.0 HP
5 : 5.0 HP

Materials of Bearing/Spindle/Liner ring

CF : High density carbon/High purity alumina ceramic/High purity alumina ceramic
RF : PTFE (with filler)/High purity alumina ceramic/High purity alumina ceramic
KK : SiC/SiC/SiC

Material of O-ring

V : FKM
E : EPDM

NEMA C-Face Motor

Impeller

X : 60Hz
Y : 60Hz
Z : 60Hz

Note: All combination of impeller and motor size are not available. Please contact Iwaki for detail.

Wet End Materials

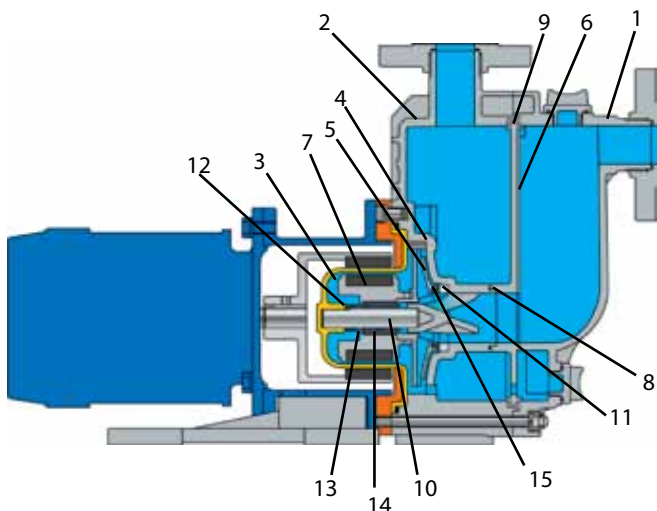

	Model	CA/CF	RA/RF	KA/KK
1	Front case	GFRPP/CFRETFE		
2	Rear case	GFRPP/CFRETFE		
3	Rear casing	GFRPP/CFRETFE		
4	Volute spacer	GFRPP/CFRETFE		
5	Impeller	GFRPP/CFRETFE		
6	Plate	GFRPP/CFRETFE		
7	Magnet capsule	GFRPP/CFRETFE		
8	O-ring	FKM/EPDM		
9	Gasket	FKM/EPDM		
10	Spindle	High Purity Alumina Ceramic		SiC
11	Liner ring	Alumina Ceramic/SiC (KK)		
12	Rear thrust	CFRPPS		
13	Rear thrust ring (RA/RF only)	---	Alumina Ceramic	---
14	Bearing	Carbon	PTFE w/filler	SiC
15	Mouth ring	PTFE w/filler		

Principles of Self-Priming

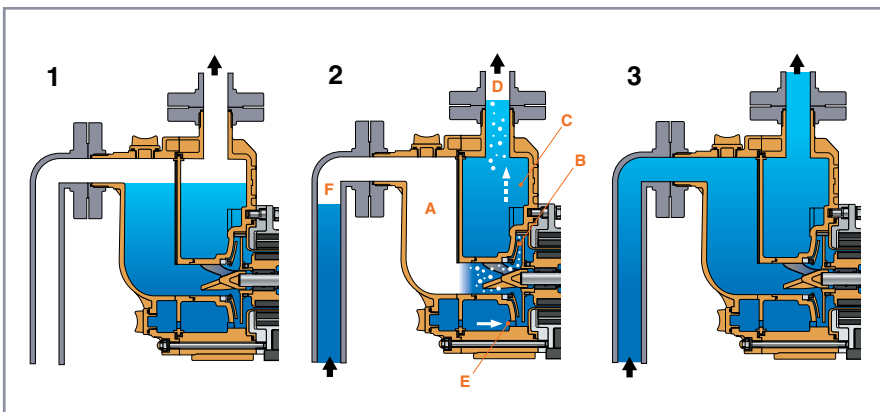

1

The pump chamber is filled with liquid initially.

2

When the operation starts, liquid and gas on the suction side are taken in through the front casing A and then mixed together by the impeller. The mixture is discharged from pump chamber B and sent to the inside rear casing C, where the liquid and gas are separated from each other. The liquid remains there and proceeds in direction E, while the gas is discharged through port D. Then the liquid goes back into pump chamber B through circulation hole E, where it is mixed again with the gas on the suction side. This process is repeated until the gas on the suction side F is completely exhausted.

3

Once the gas is completely removed and the pump is filled with liquid, the SMX works as a typical centrifugal pump. Even if the pump is stopped, sufficient liquid is retained to perform the self-priming function again.

Performance Curves

SMX
series

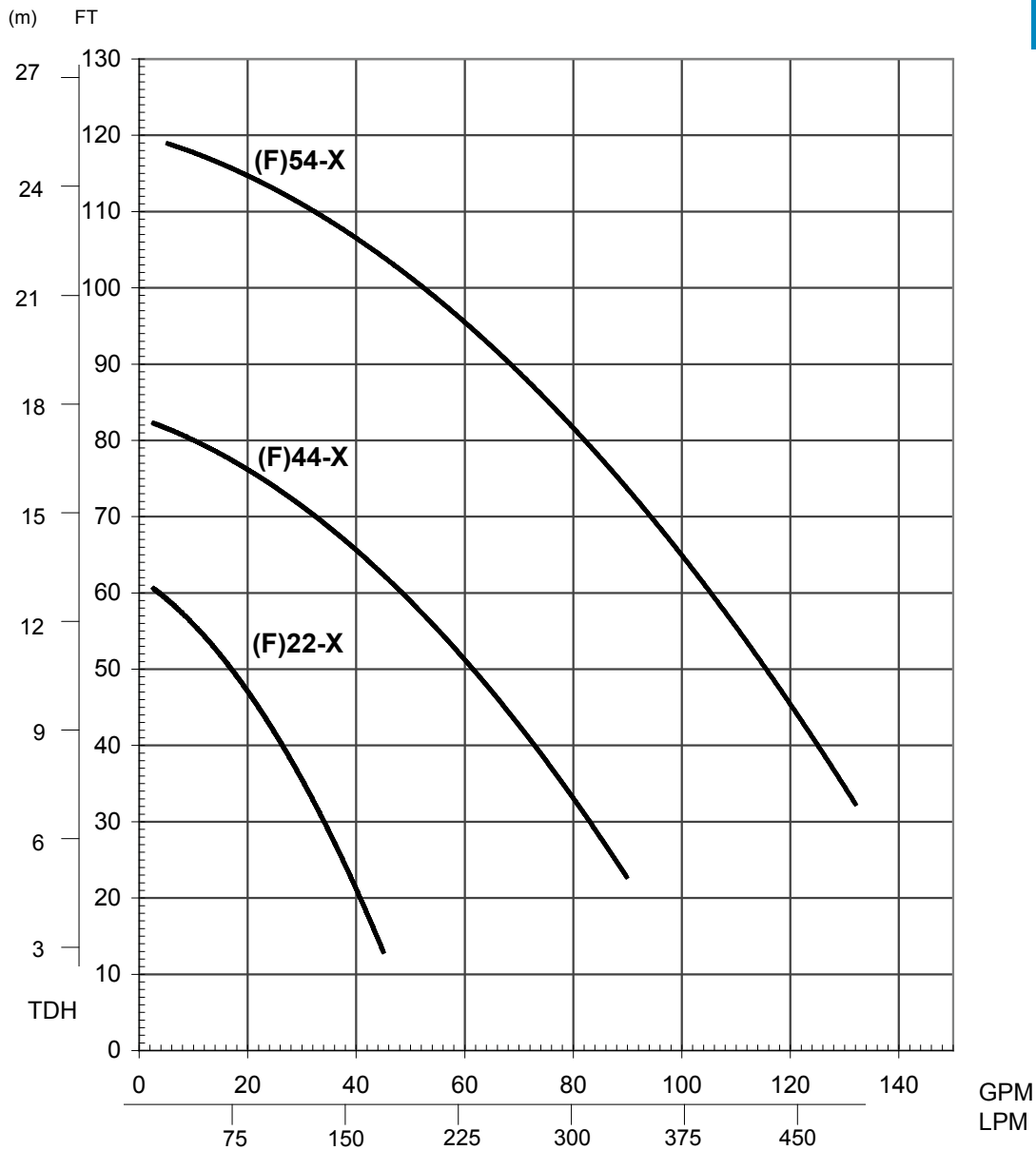

Specifications

SMX Model	Connections Suction x Discharge	Impeller Code	Max Capacity @ 60 Hz (GPM)	Max Head (FT)	Min Flow Rate (GPM)	Motor (RPM)	Motor (HP)
(F)220	1 x 1	Y	25	35	2.6	3500	½
(F)221	1 x 1	X	45	60	2.6	3500	1
(F)221	1 x 1	Y	34	35	2.6	3500	1
(F)222	1 x 1	X	45	60	2.6	3500	2
(F)441	1½ x 1½	Y	74	49	2.6	3500	1
(F)442	1½ x 1½	X	90	84	2.6	3500	2
(F)443	1½ x 1½	X	90	84	2.6	3500	3
(F)543	2 x 1½	Z	110	96	5.3	3500	3
(F)545	2 x 1½	Y	132	112	5.3	3500	5
(F)545	2 x 1½	X	132	119	5.3	3500	5

SMX-(F) Dimensions

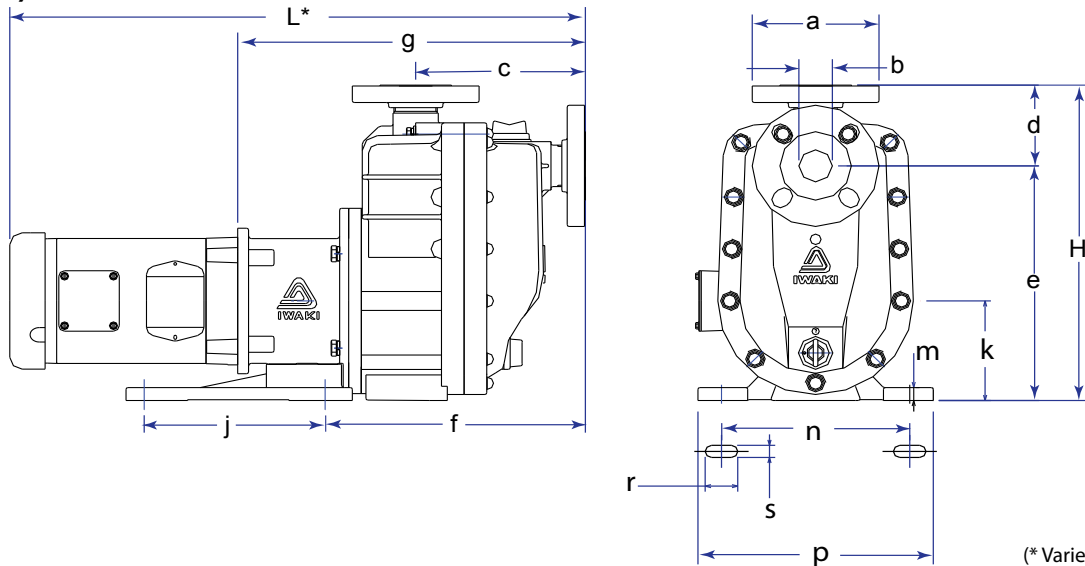

(* Varies with motor manufacturer)

Model	a	b	c	d	e	f	g	j	k	m	n	p	r	s	H	L*	HP/Frame
SMX-(F)220							12.13 (308)										0.5/56C
SMX-(F)221	4.92 (125)	0.98 (25)	6.38 (162)	2.91 (74)	10.04 (255)	9.45 (240)	12.60 (320)								12.95 (329)	21.77 (533)	1.0/56C
SMX-(F)222							13.07 (332)	7.87 (200)	4.53 (115)	0.59 (15)	8.18 (208)	10.24 (260)	1.42 (36)	0.55 (14)		23.89 (697)	2.0/145TC
SMX-(F)441							14.41 (366)									23.58 (599)	1.0/56C
SMX-(F)442	5.51 (140)	1.57 (40)	7.40 (188)	3.66 (93)	10.67 (271)	11.22 (285)	14.88 (378)								14.33 (364)	25.69 (652)	2.0/145TC
SMX-(F)443							14.88 (378)									25.69 (652)	3.0/145TC
SMX-(F)543	6.10 (155)	1.89 (48)	8.02 (204)	3.93 (100)	11.36 (288)	12.18 (309)	15.52 (394)	7.86 (200)			8.17 (208)	10.22 (260)	0.55 (14)	1.41 (36)	15.29 (388)	26.71 (678)	3.0/145TC
SMX-(F)545			8.03 (204)	3.94 (100)	11.38 (289)	12.20 (310)	16.59 (421)	10.24 (260)	5.12 (130)	0.13 (3.3)	9.06 (230)	10.24 (260)	1.42 (36)	0.55 (14)	15.31 (389)	30.28 (769)	5.0/184TC

Application Examples:

Pumping up from underground tank

- Underground tank at chemical plant.
- Underground tank or pit of waste plant.

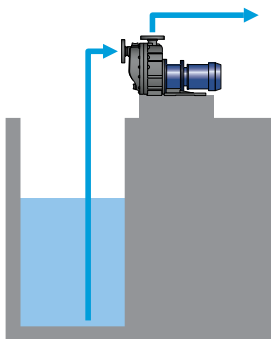

Pumping up and out from top of tank and tanker truck

- Transferring etching and plating chemical from chemical bath.
- Sucking up chemical from truck.
- Pumping up from top of tank.

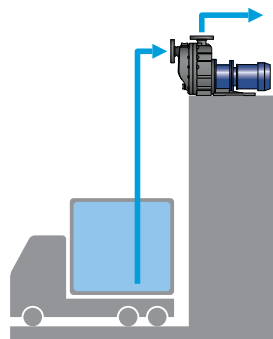

Transferring chemical from tank to tank

- Transferring from main tank to daily tank.
- Refilling chemical from drum to tank.

