



6MS50SS
Shown

MS50

Pump Volute / Impeller Materials

- 1MS50 (SS) – 316SS / 316SS (one-stage)
- 2MS50 (SS) – 316SS / 316SS (two-stages)
- 3MS50 (SS) – 316SS / 316SS (three-stages)
- 4MS50 (SS) – 316SS / 316SS (four-stages)
- 5MS50 (SS) – 316SS / 316SS (five-stages)
- 6MS50 (SS) – 316SS / 316SS (six-stages)

Features

- **Pump Design** – Compact, close coupled
- **Double Seal** – Type 21 available
- **Flush Options** – Recirculating, & Quench available
- **Stub Shaft** – Replaceable 316SS shaft

Applications

- Deionized Water
- Laser System Cooling
- Ultrafiltration Systems
- Reverse Osmosis Systems
- Booster Pumps
- Acid Handling

Optional Configurations

- **Air Motor:** Up to 2-1/2 HP
- **Power Frame Mounting:**

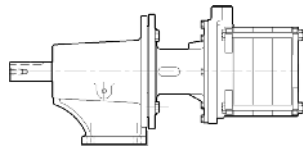

- **Long-Coupled Mounting:**

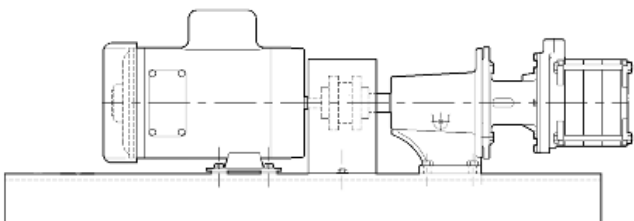

Standard Specifications

- MS50 Discharge 1/2" FNPT, Suction 3/4" FNPT
- Maximum Impeller Diameter: 4.12"
- Stub Shaft: 5/8" 316SS (7/8" Optional)
- Motor: NEMA C Face (Multiple enclosures available)
- Mechanical Seal:
 - Single, 5/8" Type 21 Viton, Carbon vs. Ceramic
 - Note: Additional seal options available*
- Bracket Material: 316SS
- O-rings: Viton, (Call for other options)

Performance Curve – 60 Hz

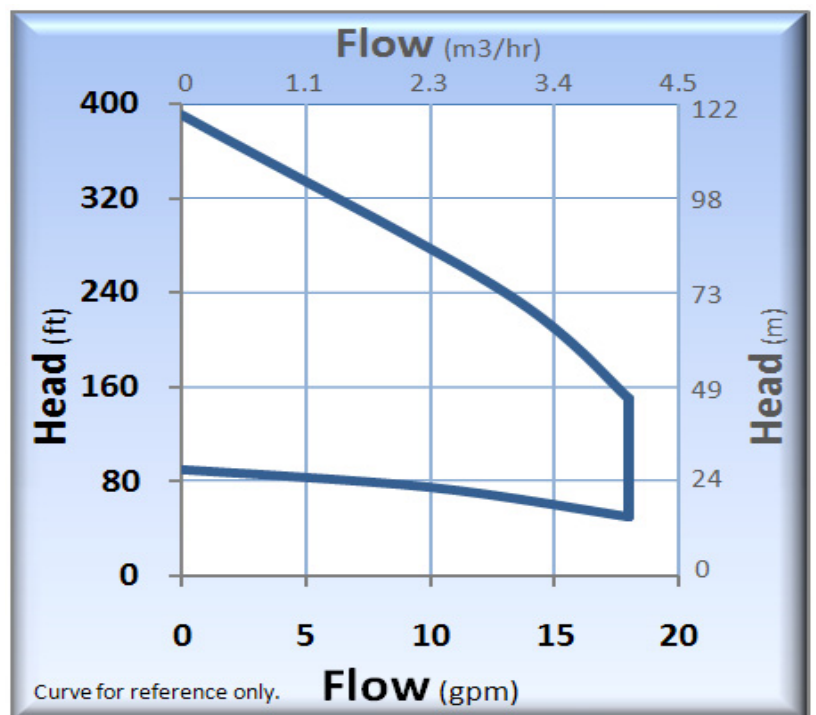

MS50

Technical Information	
Max Flow	18 GPM (4.1 m3/hr)
Max Head	390 feet (119 m)
Min. Flow	0.5 GPM (0.1 m3/hr)
Max Solid Size	0.030" (0.76 mm)
Max Working Pressure	(Type 8 Seal) 325 PSI (22.4 bar)
	(Type 9 Seal) 350 PSI (24.1 bar)
	(Type 21 Seal) 150 PSI (10.3 bar)
	(Type 2106 Seal) 150 PSI (10.3 bar)
Max Temp.	300°F (149°C)*

Materials of Construction	
MS50	SS
Volute / Suction Plate	316 Stainless Steel
Impeller	316 Stainless Steel
Diffusers	316 Stainless Steel
Stage Separators	316 Stainless Steel
Bracket	316 Stainless Steel
O-rings	Viton
Fasteners	316 Stainless Steel

* Temperature limits are based on standard seal and O-ring materials, and will vary according to the liquid being pumped.

Dimensions (MS50)

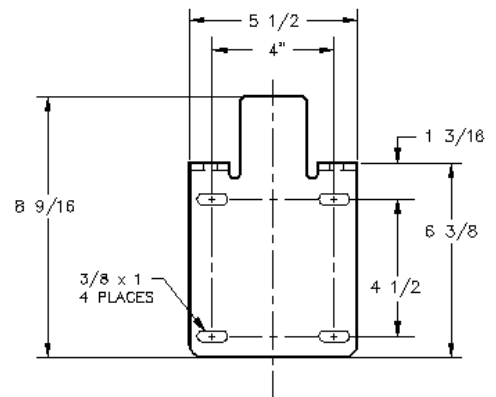
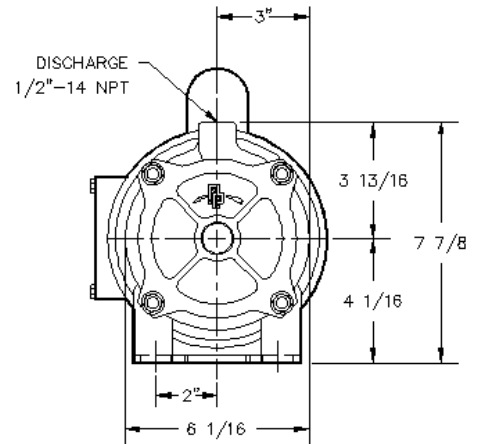
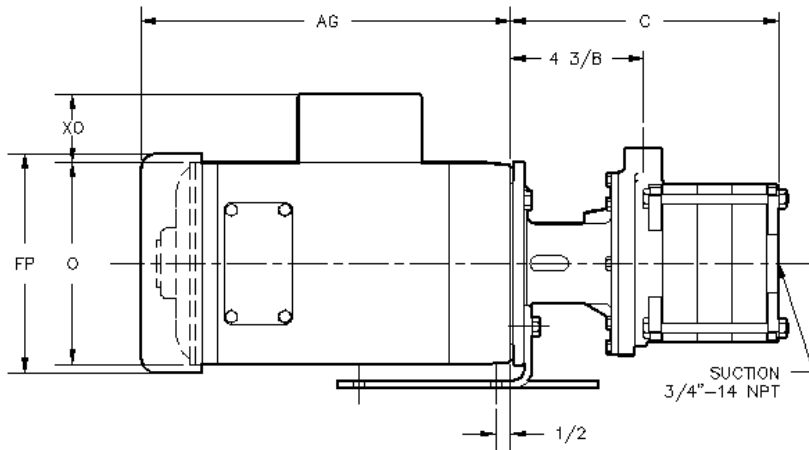

HP	RPM	FRM	MOTOR END DIMENSIONS			
			AG	FP	O	XD
1/4	1800	56C	7 3/4	6 1/8	5 3/8	2 1/16
1/3	1800	56C	8 1/4	6 1/8	5 3/8	2 1/16
1/2	1800	56C	8 3/4	6 1/8	5 3/8	2 1/16
1/3	3600	56C	8 1/2	6 1/8	5 3/8	2 1/16
1/2	3600	56C	8 3/4	6 1/8	5 3/8	2 1/16
3/4	3600	56C	9 1/4	6 1/8	5 3/8	2 1/16
1	3600	56C	9 3/4	6 1/8	5 3/8	2 1/16
1 1/2	3600	56C	10 1/2	7 3/16	6 7/8	2 1/4
2	3600	56C	11 1/8	7 3/16	6 7/8	2 1/4
3	3600	56C	12 3/8	7 3/16	6 7/8	2 1/4
5	3600	184C	13 5/8	8 1/2	7 7/8	2 1/4

PUMP LENGTH: (IN INCHES)		
MODEL	STAGES	C
1MS50-SS-33	1 STAGE	5 3/8
2MS50-SS-75	2 STAGE	6 1/2
3MS50-SS-100	3 STAGE	7 5/8
4MS50-SS-150	4 STAGE	8 3/4
5MS50-SS-200	5 STAGE	9 7/8
6MS50-SS-300	6 STAGE	11

NOTE:
MOTOR DIMENSIONS WILL VARY BY MODEL AND MAKE,
DIMENSIONS ARE TO BE USED FOR REFERENCE ONLY.

PRICE PUMP CO.

Contact factory for special pump configurations,
same day, and next day delivery options.

21775 Eighth Street East
Sonoma, CA 95476-0329
MAIN (707) 938-8441
TOLL FREE (800) 345-7867
FAX (707) 938-0764
E-mail: sales@pricepump.com
Website: www.pricepump.com

Member of:
Hydraulic INSTITUTE



Rev. Date: May 2009