



Features

- **Pump Design** – Compact, close coupled
- **Double Seal** – Type 9 & 21 available
- **High Pressure Option** – 300 PSI maximum
- **Teflon Seal** – Type 9 available
- **Flush Options** – Recirculating & Quench available

Applications

- Waste Water Treatment
- Hot Solvents
- Deionized Water
- Chemical Process
- Plating Equipment
- Agricultural Chemicals

Optional Configurations

- **Air Motor:** Up to 2-1/2 HP
- **Vertical Mounting:**
- **Power Frame Mounting:**
- **Long-Coupled Mounting:**

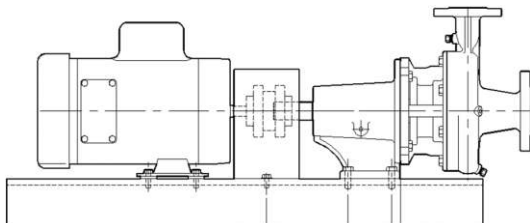
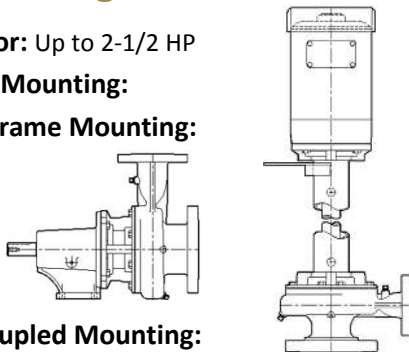

XL100/150/200

Pump Volute / Impeller Materials

XL (SS) – 316SS / 316SS

Standard Specifications

- XL100 / XL100V Discharge 1", Suction 1-1/2" ANSI Flanges
- XL150 / XL150V Discharge 1-1/2", Suction 3" ANSI Flanges
- XL200 / XL200V Discharge 2", Suction 3" ANSI Flanges
Flanges: 150 lb. Centerline ANSI Dimensioned
- Maximum Impeller Diameter: 5.98"
- Shaft Sleeve: 316SS
- Motor: NEMA JM Face (Multiple enclosures available)
- Mechanical Seal:
Single, 1-1/2" Type 21 Buna, Carbon vs. Ceramic (AI, BF, SF, AB)
Single, 1-1/2" Type 21 Viton, Carbon vs. Ceramic (SS)
Note: Additional seal options available
- Bracket Material: Stainless Steel, Bronze, & Cast Iron
- Gasket: Syn. Fiber (AI, BF, AB, SF) and PTFE (SS)

Performance Curve – 60 Hz

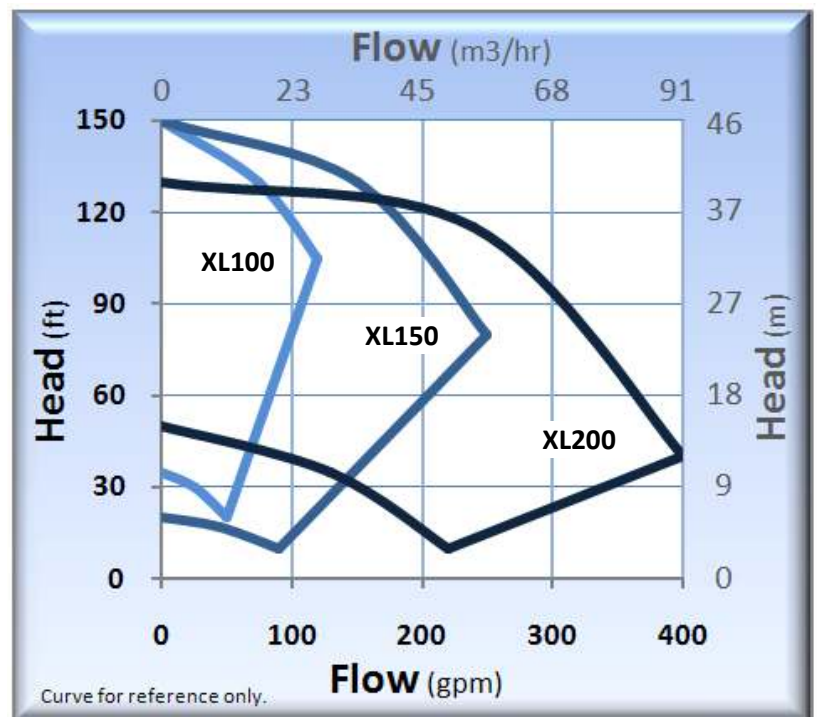

XL100/150/200

Technical Information		
Max Flow	(XL100)	120 GPM (27 m3/hr)
Max Flow	(XL150)	250 GPM (57 m3/hr)
Max Flow	(XL200)	400 GPM (95 m3/hr)
Max Head		150 feet (46 m)
Min. Flow	(XL100)	10 GPM (2.3 m3/hr)
Min. Flow	(XL150)	35 GPM (7.9 m3/hr)
Min. Flow	(XL200)	50 GPM (11.4 m3/hr)
Max Solid Size	(XL100)	0.120" (3.0 mm)
Max Solid Size	(XL150)	0.190" (4.8 mm)
Max Solid Size	(XL200)	0.250" (6.4 mm)
Max Working Pressure	(Type 8 Seal)	325 PSI (22.4 bar)
	(Type 9 Seal)	350 PSI (24.1 bar)
	(Type 21 Seal)	150 PSI (10.3 bar)
	(Type 2 Seal)	300 PSI (20.6 bar)
Max Temp.		300°F (149°C)*

Materials of Construction	
XL	SS
Volute	316SS
Impeller	316SS
Bracket	316SS
Gasket	Teflon
Fasteners	316 SS

* Temperature limits are based on standard seal and gasket materials, and will vary according to the liquid being pumped.

Dimensions (XL)

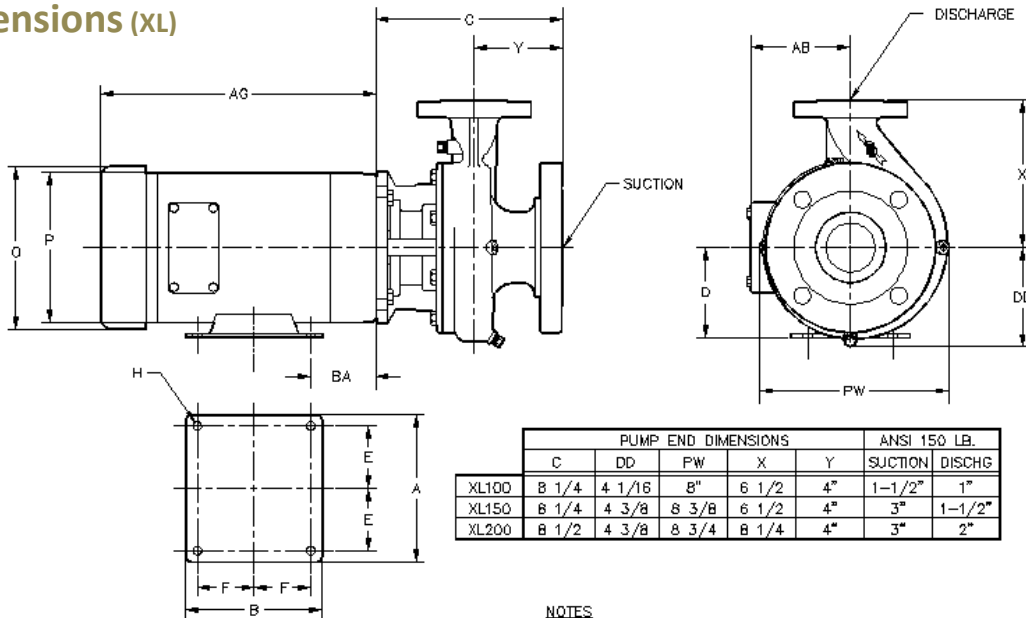

NOTES
ALL DIMENSIONS ARE ROUNDED TO THE NEAREST 1/8 INCH.

HP	RPM	FRM	JM MOTOR END DIMENSIONS								DDP		TEFC & EXP. PRF				
			A	B	D	E	F	H	BA	D	P	AB	AG	AB	AG		
1 1/2	3600	143JM															
2	3600	145JM	6-1/2	5-15/16	3-1/2	2-3/4	2	11/32	2-7/8	6-7/8	6-5/8	5-1/4	8-3/4	6-3/4	11-1/4		
3	3600	145JM					2-1/2										
5	3600	182JM	8-1/2	6-1/2	4-1/2	3-3/4	2-1/4	13/32	3-1/2	8-7/16	7-7/8	5-7/8	11-1/8	7-3/8	14-3/4		
7 1/2	3600	184JM					2-3/4										
10	3600	215JM	9-1/2	8	5-1/4	4-1/4	3-1/2	13/32	4-1/2	10-1/16	9-9/16	N/A	7-3/8	14-3/4			
15	3600	215JM															

NOTE: MOTOR DIMENSIONS WILL VARY BY MODEL AND MAKE. DIMENSIONS ARE TO BE USED FOR REFERENCE ONLY.
10 AND 15 HP MOTORS ARE BALDOR 215 JM W/ 184 FACE.

**Contact factory for special pump configurations,
same day, and next day delivery options.**

PRICE PUMP CO.

21775 Eighth Street East
Sonoma, CA 95476-0329

MAIN (707) 938-8441

TOLL FREE (800) 345-7867

FAX (707) 938-0764

E-mail: sales@pricepump.com

Website: www.pricepump.com

Member of:
Hydraulic INSTITUTE



Rev. A Date: July 2012